

Zentrifugalpumpe mit Magnetkupplung Magnetically coupled centrifugal pump NEMP 40/4

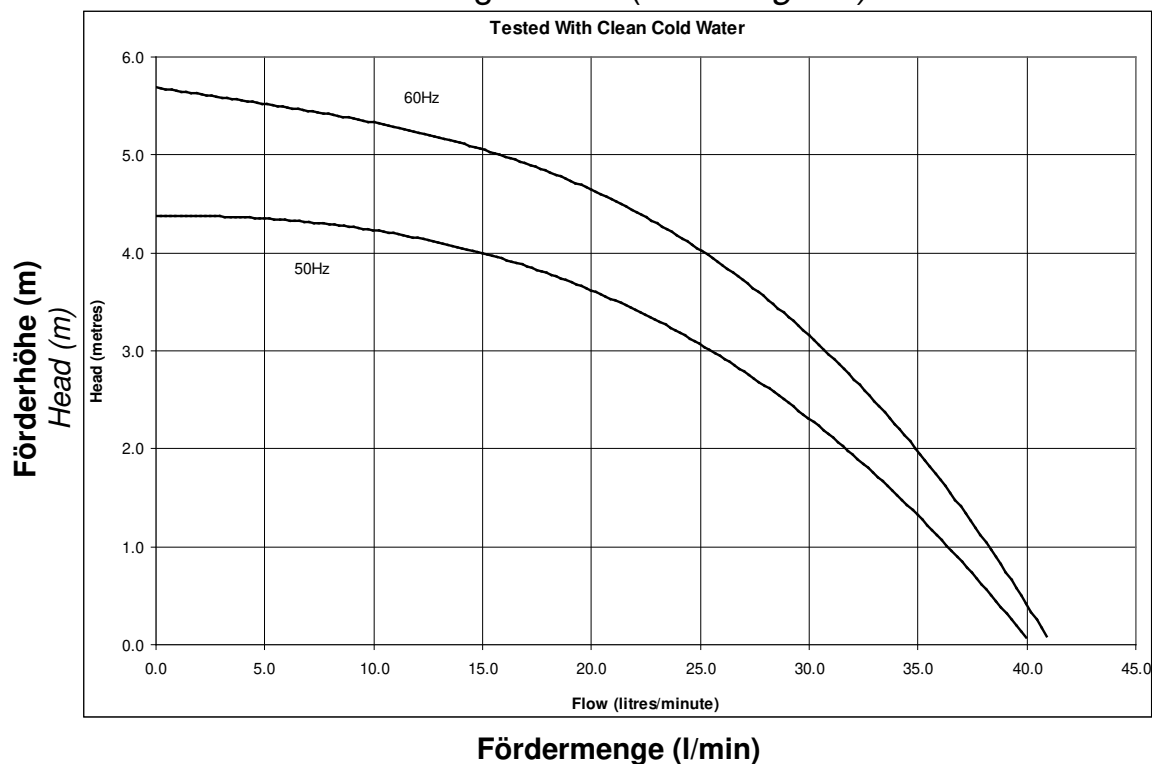

Leistungskurve* (load diagram)*



Typ Type	Volt	Ph	Hz	Saugstutzen inlet port	Druckstutzen discharge side	Artikel-Nr. PP Item number	Artikel-Nr. PPS Item number
NEMP 40/4	230	1	50	Ø 21mm glatt (plain)	Ø 21mm glatt (plain)	406913	
NEMP 40/4	230	1	50	½" BSP AG (M)	½" BSP AG (M)	406943	
NEMP 40/4	110	1	50	Ø 21mm glatt (plain)	Ø 21mm glatt (plain)		
NEMP 40/4	110	1	60	½" BSP AG (M)	½" BSP AG (M)	416918	
NEMP 40/4	110	1	60	Ø 21mm glatt (plain)	Ø 21mm glatt (plain)	106936	

* Die Leistungskurve wurde mit Wasser bei 20°C ermittelt * Performance tested with clean cold water @ 20°C

Zentrifugalpumpe mit Magnetkupplung Magnetically coupled centrifugal pump NEMP 40/4

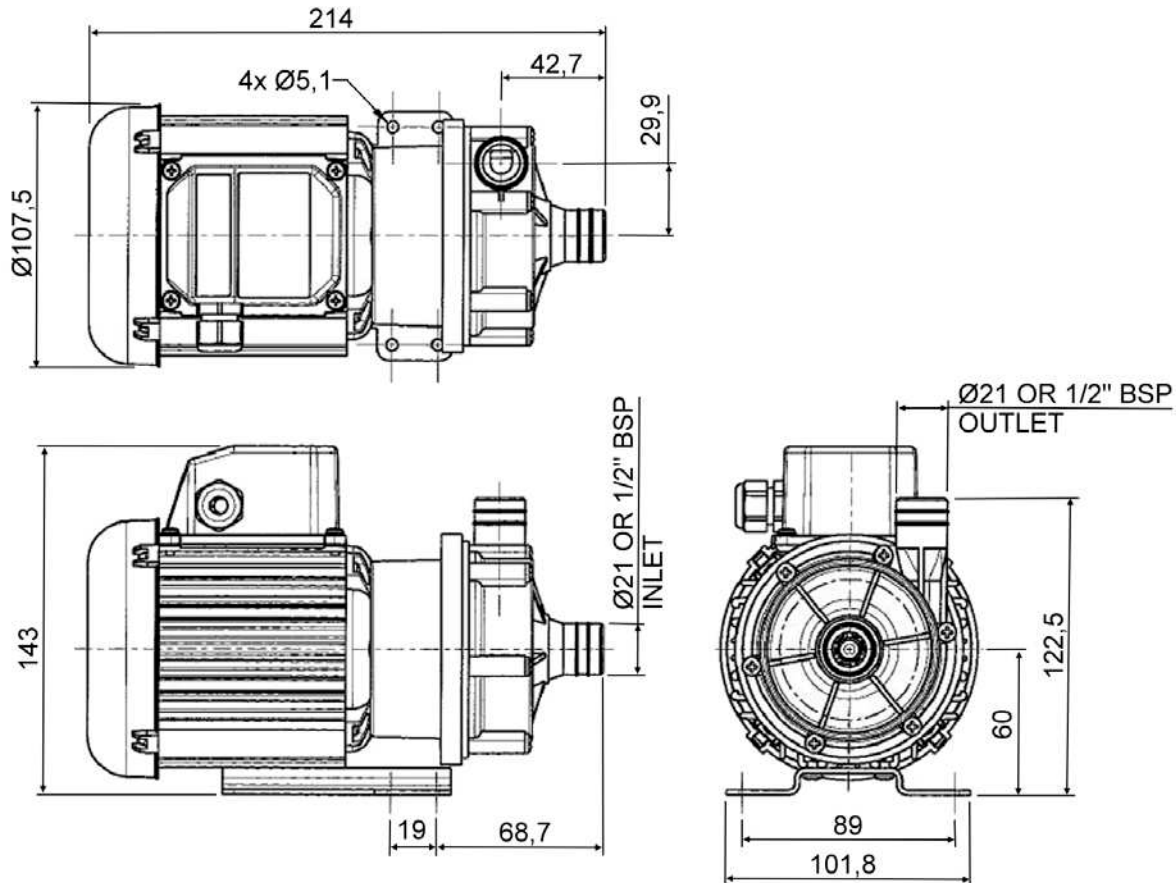

Technische Daten (Technical data) NEMP 40/4

max. Fördermenge	(discharge rate)	40 l/min (50Hz)	41 l/min (60Hz)
max. Förderhöhe	(delivery head)	4,4 m (50Hz)	5,7 m (60Hz)
Temperaturbereich	(temperature range)	-20...+85°C (PP)	
max. Dichte	(max. specific gravity)	1,2 Kg/dm ³ @ max. 30 mPa s	
Gehäusedruck	(pump casing pressure)	1,4 bar	
Saugstutzen	(inlet port)	1/2" BSP AG (M)	Ø 21 mm glatt (plain)
Druckstutzen	(discharge side)	1/2" BSP AG (M)	Ø 21 mm glatt (plain)
Gehäusematerial	(pump casing material)	PPH	PPS
Flügelrad	(impeller)	PPR	PPR
Welle	(spindle material)	Keramik (Ceramic)	
O-Ring	(o-ring)	EPDM alternativ NBR, VITON	
Motor	(motor)	230 V, 1 Ph, 50Hz	230 V, 1 Ph, 60 Hz
		110 V, 1 Ph, 50 Hz	110 V, 1 Ph, 60 Hz
Leistung	(motor capacity)	60 Watt	
Schutzart	(protection category)	IP 54	
Gesamtgewicht	(total weight)	~ 2,7kg	

Achtung: Die Pumpen sind nicht selbstansaugend und nicht für Trockenlauf geeignet.

Attention: These magnetically pumps are designed for use with clean fluids. Solids will cause jamming. Abrasives will reduce pump live and invalidate the warranty. The pumps are not designed to run dry.

Zentrifugalpumpe mit Magnetkupplung Magnetically coupled centrifugal pump NEMP 40/4

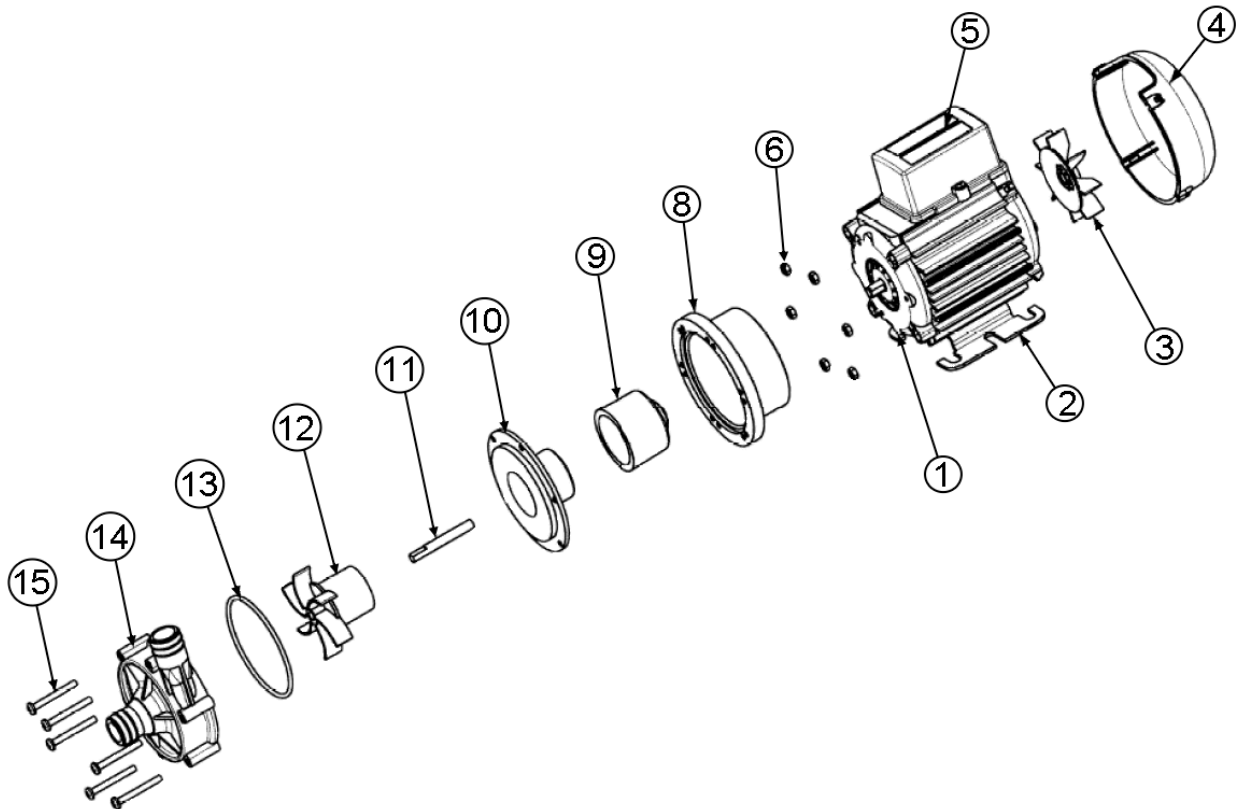

Typ	Pos.	Beschreibung	Description	Stück	Artikel-Nr.	zusätzl. Angaben
NEMP 40/4	1	Motor	Motor	1	116849	230 V
					116874	110 V
NEMP 40/4	2	Montagefuß	Mounting Foot	1	036329	
NEMP 40/4	3	Lüfterrad	Fan CBM Motor	1	036067	
NEMP 40/4	4	Lüfterabdeckung	Fan Cowl	1	036085	
NEMP 40/4	5	Anschlusskasten	Terminal Box	1	036078	
NEMP 40/4	6	Mutter M4 DIN 934	Nut	6	032105	
NEMP 40/4	8	Laterne	Adaptor	1	036324	Nylon
NEMP 40/4	9	Antriebsmagnet	Drive Magnet	1	006287	
NEMP 40/4	10	Spindelgehäuse	Spindle Housing	1	016311	PPS
NEMP 40/4	11	Spindel	Spindle	1	006244	Standard
					036347	99,5% Al
NEMP 40/4	12	Flügelrad	Impeller	1	026214	50Hz, PPR
					026213	60Hz, PPR
NEMP 40/4	13	O-Ring	O-Ring	1	013290	EPDM
					021056	Viton
					003398	Nitrile
NEMP 40/4	14	Pumpengehäuse	Pump Body	1	016358	Ø 21mm PPH
					016366	Ø 21mm PPS
					016360	½" BSP PPH
					016368	½" BSP PPS
NEMP 40/4	15	Schraube M4x35 DIN 7985	Screw	6	022115	