

Centrifugalpumpe mit Magnetkupplung *Magnetically coupled centrifugal pump* Typ: HCP ES



Kenndaten:

- Fördermengen bis 30 m³/h
- Förderhöhe bis 24 m,
- Mediumtemperatur max.: 160 °C
- Mediumberührte Teile Edelstahl AISI 316, EPDM, Viton, Carbon/Carbon/PTFE
- Welle Hastelloy C276,
- Der magnetgetriebene Impeller reduziert die Wartungskosten.
- Max Viskosität 200 cSt
- Druckstufe PN 10 bei 20°C

Standardausführung:

- Saug- und Druckstutzen Innengewinde
- Magnetkupplung mit hohem Drehmoment

Optionen:

- Flanschstutzen nach DIN / EN und ANSI 150
- Schnellanschlüsse
- ATEX
- Trockenlaufschutz
- Motor 60Hz
- Motor EX-Schutz
- Motor 4-polig
- Kaltleiter
- Saugfilter

Features:

- Flow up to 30 m³/h
- head up to 24 m
- FLUID-Temp: max. 160°C
- Wetted Parts: Stainless Steel AISI 316 EPDM, Viton, Carbon/Carbon/PTFE
- Shaft Hastelloy C276
- Separate impeller minimizes maintenance costs.
- Max viscosity : 200 mPa s
- Pressure Rating NP 10 at 20°C

Standard:

- Thraeded In and Outlet Connection
- High torque magnetic coupling

Optional:

- DIN / EN and ANSI 150 Flanges available
- QUICK CONNECTING DEVICE
- ATEX
- Dry run protector
- OTHER VOLTAGES / 60 Hz
- EXPLOSION PROOF MOTOR
- 1450 rpm MOTOR
- OVERLOAD SWITCH
- SUCTION STRAINER

HCP ES – 6 – 10 MAßE / DIMENSION

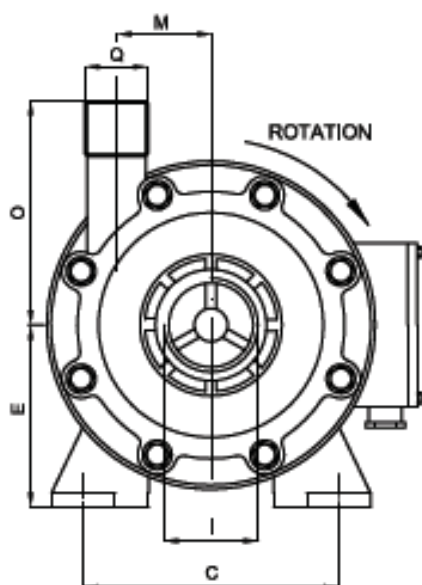
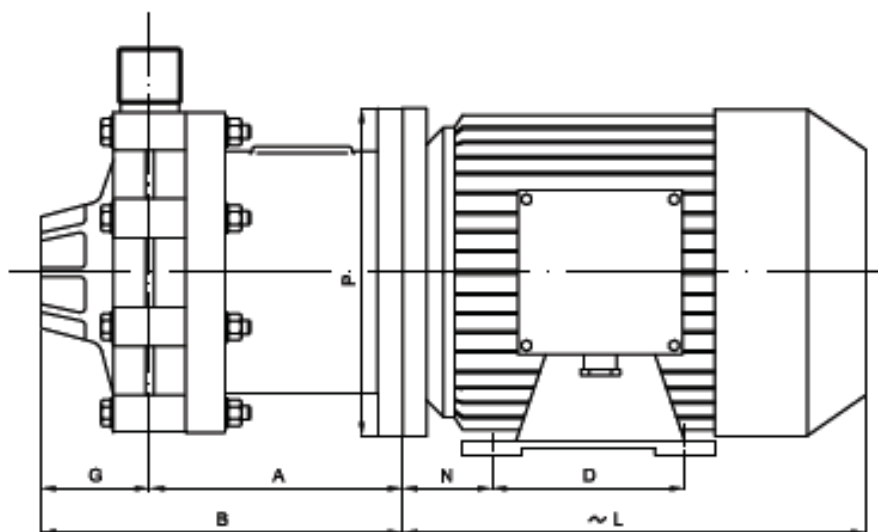

Pump Typ	Motor Flansch Flange Motore B3-B5	Mot or kW	Maße / Dimension's in mm														
			A	B	C	D	E	F	G	H	I	~L	M	N	O	P	Q
HCP ES6-SS316	G 71 B	0,55	137	194	112	90	71	-	57	4	1" IG Female	204	46	45	89	160	3/4" AG Male
HCP ES 10-SS316	G 80 B	1,1	143	212	125	100	80	-	69	7	1 1/2" IG Female	224	44	50	98	200	1" AG Male

HCP ES – 15 – 31 MAßE / DIMENSION

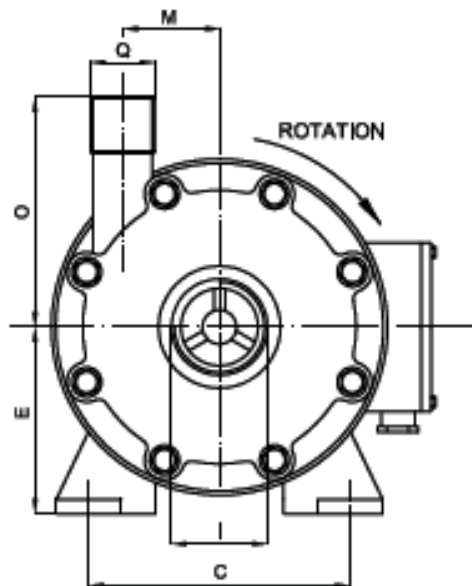
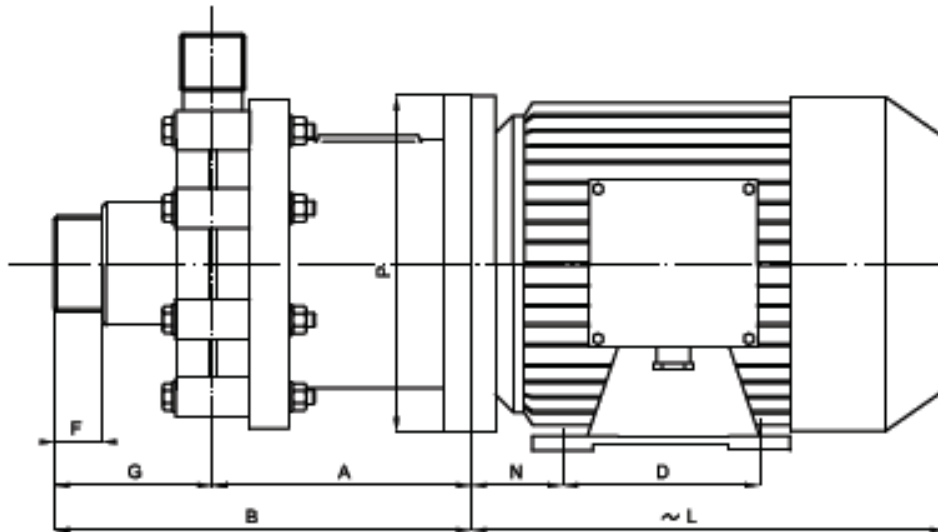

Pump Typ	Motor Flansch Flange Motore B3-B5	Motor kW	Maße / Dimension's in mm														
			A	B	C	D	E	F	G	H	I	~L	M	N	O	P	Q
HCP ES 15 SS316	G 90 S	1,5	177	257	140	100	90	28	80	112	2" G Male	252	66	56	135	160	1 1/2" AG Male
HCP ES 31 SS316	G 90 L	2,2	187	278	140	1250	90	30	91	139	2 1/2" G Male	272	66	56	140	200	2" AG Male

Centrifugalpumpe mit Magnetkupplung Magnetically coupled centrifugal pump HCP ES

Leistungskurve* (load diagram)*
50 Hz @ 2900 min⁻¹

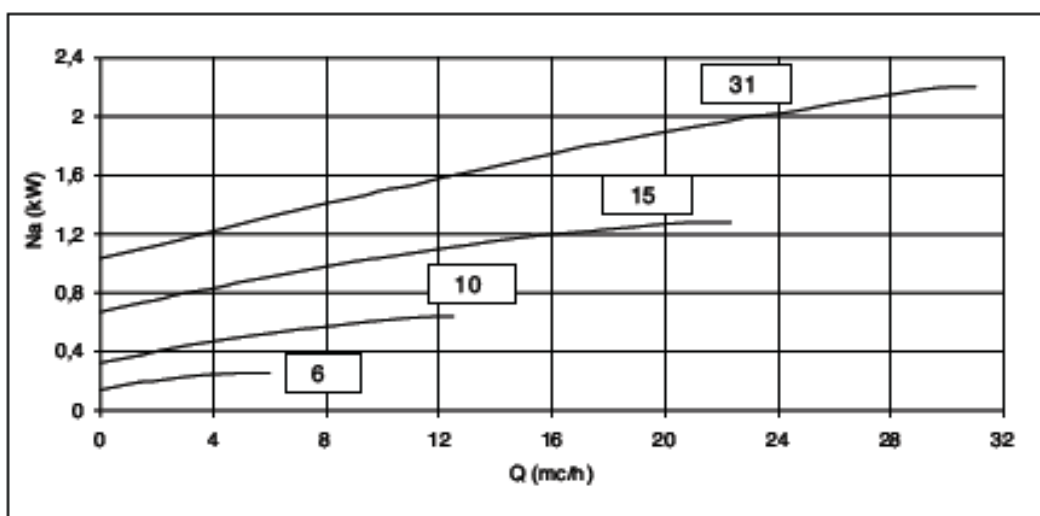
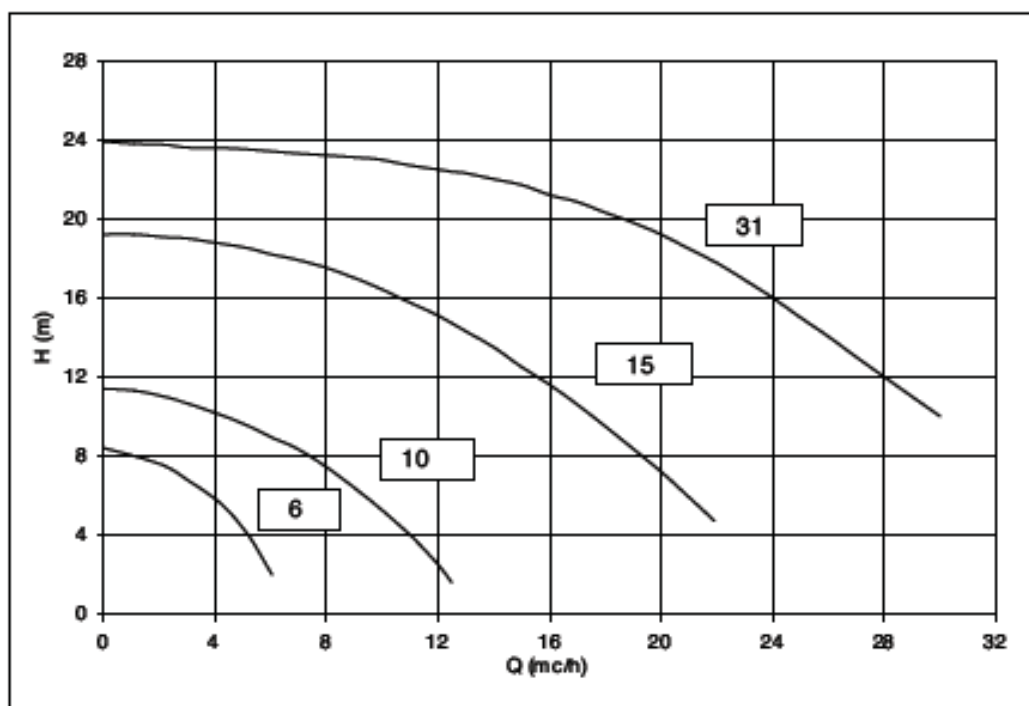

* Die Leistungskurven wurden mit Wasser bei 20°C ermittelt * Performance tested with clean cold water @ 20°C

SCHNITT UND ERSATZTEILE SECTION AND PARTLIST HCP ES 6 - 10 - 15 - 31

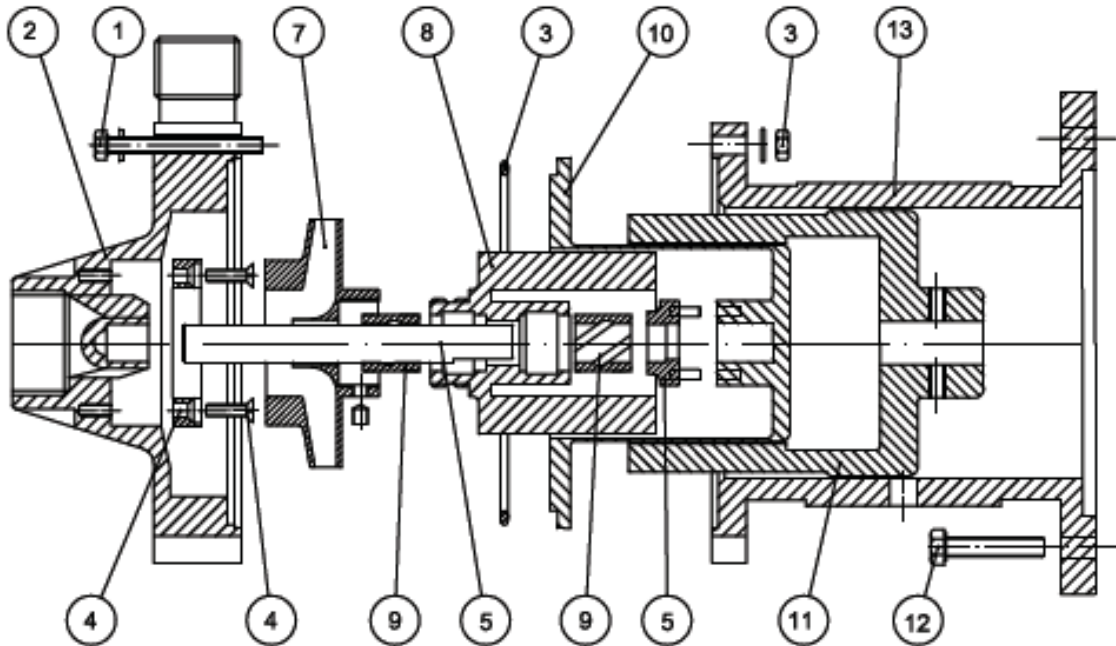

POS:	1	2	3	4	5	7
Benennung Description	Satz Schrauben Set Screws	Front Casing Frontgehäuse	O-Ring	Gehäuse Sicherung Casing Trust Bush	Shaft+Ring Welle+Ring	Impeller Flügelrad
Werkstoff Material	Edelstahl A2	Edelstahl AISI 316	Viton	PTFEC CARBON	HC276+ AISI 316	Edelstahl AISI 316
POS:	8	9	10	11	12	13
Benennung Description	Innerer Magnet Internal Magnet	Wellen- hülse Shaft Sleeve	Rear Casing Hinteres Gehäuse	Antriebs- magnet External Magneet	Schrauben Screws	Laterne Bracket
Werkstoff Material	Edelstahl AISI 316	PTFEC CARBON	Edelstahl AISI 316	C-Stahl Carbon-Steel	Edelstahl A2	Aluminium

* Die Leistungskurve wurde mit Wasser bei 20°C ermittelt * Performance tested with clean cold water @ 20°C