

Zentrifugalpumpe mit Magnetkupplung Magnetically coupled centrifugal pump NEMP 200/12

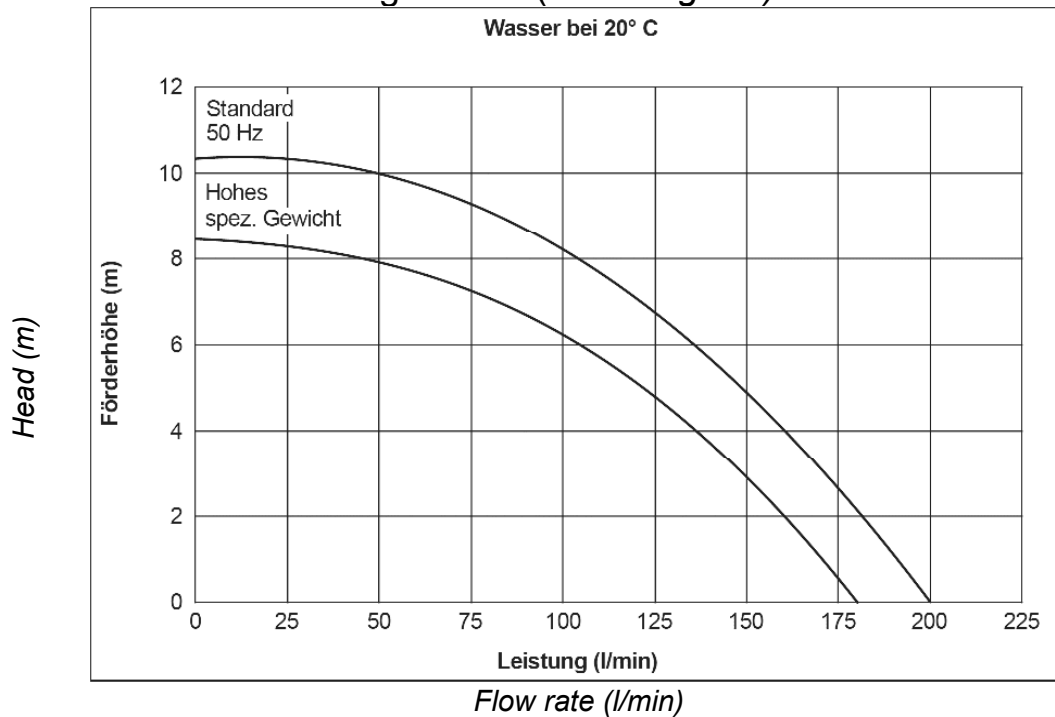

Leistungskurve* (load diagram)* 50Hz



Typ Type	Volt	Ph	Hz	Saugstutzen inlet port	Druckstutzen discharge side	Artikel-Nr. PP Item number	Artikel-Nr. PVDF Item number
NEMP 200/12	230	1	50	1½" BSP AG (M)	1" BSP AG (M)	028915	028917
NEMP 200/12	110	1	50	1½" BSP AG (M)	1" BSP AG (M)	028965	
NEMP 200/12	415	3	50	1½" BSP AG (M)	1" BSP AG (M)	028916	028918

* Die Leistungskurve wurde mit Wasser bei 20°C ermittelt. Ausführung für hohe Dichte möglich

* Performance tested with clean cold water @ 20°C. High specific gravity versions build to order.

Zentrifugalpumpe mit Magnetskupplung Magnetically coupled centrifugal pump NEMP 200/12

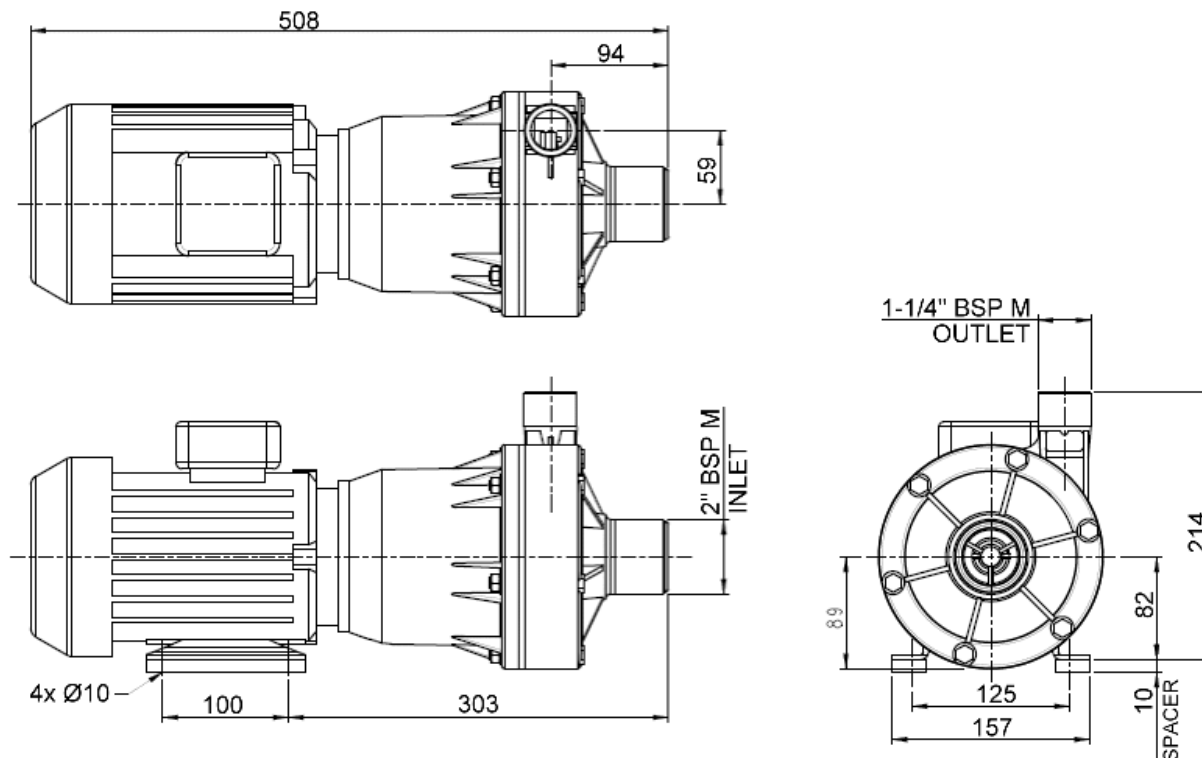

Technische Daten (Technical data) NEMP 200/12

max. Fördermenge <i>(discharge rate)</i>	200 l/min (50Hz)	
max. Förderhöhe <i>(delivery head)</i>	10,5 m (50Hz)	
Temperaturbereich <i>(temperature range)</i>	-20...+85°C (PP)	-20...+95°C (PVDF)
max. Dichte <i>(max. specific gravity)</i>	1,2 Kg/dm ³ @ max. 30 mPa s	
Gehäusedruck <i>(pump casing pressure)</i>	2,0 bar	
Saugstutzen <i>(inlet port)</i>	1 1/2" BSP AG (M)	
Druckstutzen <i>(discharge side)</i>	1" BSP AG (M)	
Gehäusematerial <i>(pump casing material)</i>	PP	PVDF
Flügelrad <i>(impeller)</i>	PP	PVDF
Welle <i>(spindle material)</i>	Keramik (Ceramic)	
O-Ring <i>(o-ring)</i>	EPDM alternativ NBR, VITON	
Motor <i>(motor)</i>	230 V, 1 Ph, 50Hz	415 V, 3 Ph, 50 Hz
Leistung <i>(motor capacity)</i>	825 Watt	
Schutzart <i>(protection category)</i>	IP 55	
Gesamtgewicht <i>(total weight)</i>	~ 9,6 kg	

Achtung: Die Pumpen sind nicht selbstansaugend und nicht für Trockenlauf geeignet.

Attention: These magnetically pumps are designed for use with clean fluids. Solids will cause jamming.

Abrasives will reduce pump live and invalidate the warranty. The pumps are not designed to run dry.

Zentrifugalpumpe mit Magnetkupplung Magnetically coupled centrifugal pump NEMP 200/12

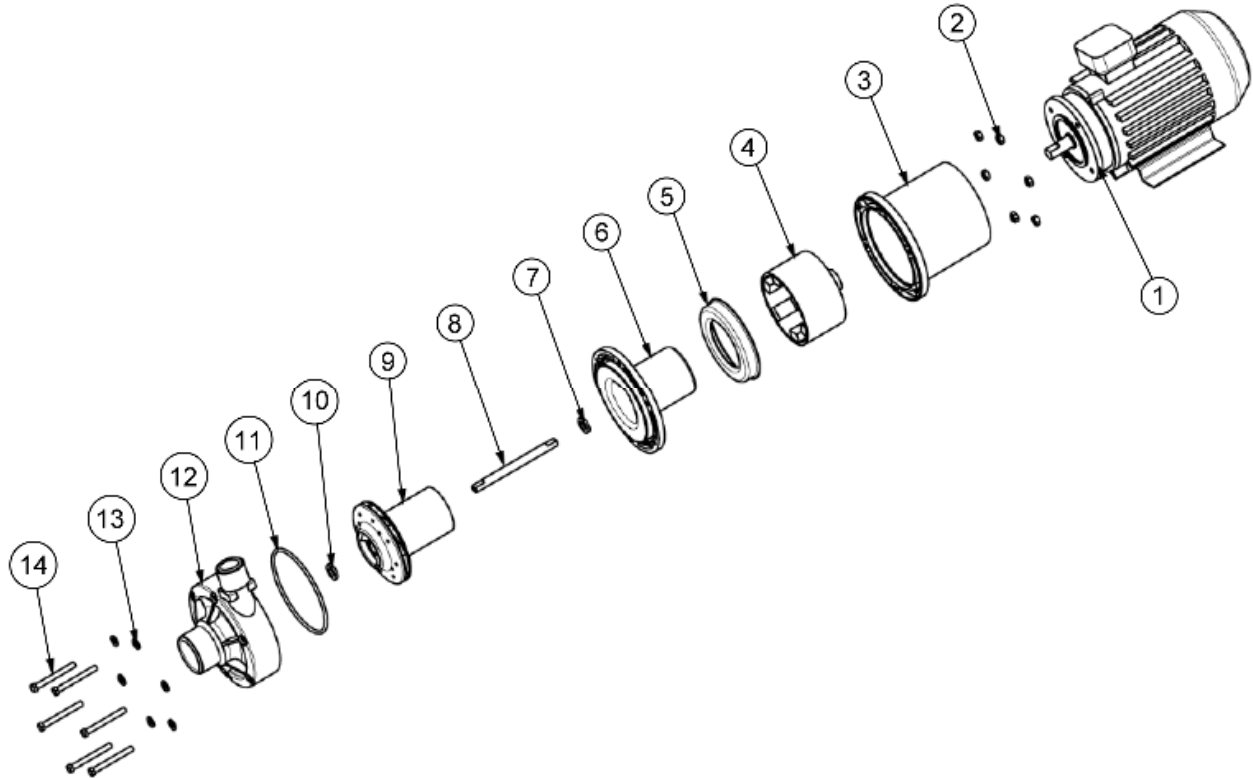

Typ	Pos.	Beschreibung	Description	Stück	Artikel-Nr.	zusätzl. Angaben
NEMP 200/12	1	Motor	Motor	1	008844	110V 1Ph 50Hz
					008831	110V 1 Ph 60Hz
					008825	230V 1Ph 50Hz
					008826	400V 3Ph 50Hz
					008847	400V 3Ph 60Hz
NEMP 200/12	2	Mutter	Nut	6	032105	
NEMP 200/12	3	Laterne	Adaptor	1	018381	
NEMP 200/12	4	Antriebsmagnet	Drive Magnet	1	008646	
NEMP 200/12	5	Zentrierscheibe	Support Plate	1	008352	
NEMP 200/12	6	Spindelgehäuse	Spindle Housing	1	018317	PPS
					008355	PVDF
					008354	PP
NEMP 200/12	7	GD-leitscheibe	D Washer	1	008298	
NEMP 200/12	8	Spindel	Spindle	1	008351	
NEMP 200/12	9	Flügelrad	Impeller	1	038601	50Hz PP
					018644	50Hz PVDF
					018671	60Hz PP
					018672	60Hz PVDF
					018627	High SG PP
					018672	High SG PVDF
NEMP 200/12	10	D-Gleitscheibe	D Washer	1	008298	
NEMP 200/12	11	O-Ring	O-Ring	1	008277	EPDM
					008235	Viton
NEMP 200/12	12	Pumpengehäuse	Pump Body	1	018380	PP
					008359	PVDF
NEMP 200/12	13	Mutter	Nut	1	001568	
NEMP 200/12	14	Schraube	Screw	6	001792	