

Zentrifugalpumpe mit Magnetkupplung Magnetically coupled centrifugal pump NEMP 120/8

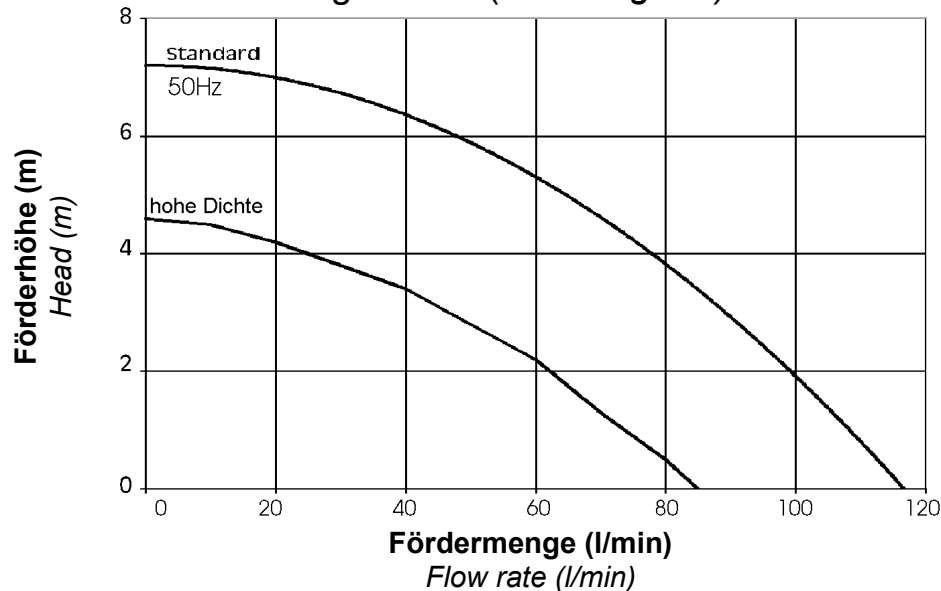

Leistungskurve* (load diagram)* 50Hz



Typ Type	Volt	Ph	Hz	Saugstutzen inlet port	Druckstutzen discharge side	Artikel-Nr. PP Item number	Artikel-Nr. PVDF Item number
NEMP 120/8	230	1	50	1¼" BSP AG (M)	¾" BSP AG (M)	028907	028909
NEMP 120/8	110	1	50	1¼" BSP AG (M)	¾" BSP AG (M)	028973	
NEMP 120/8	110	1	60	1¼" BSP AG (M)	¾" BSP AG (M)	028939	
NEMP 120/8	415	3	50	1¼" BSP AG (M)	¾" BSP AG (M)	028908	028930

* Die Leistungskurve wurde mit Wasser bei 20°C ermittelt. Ausführung für hohe Dichte möglich

* Performance tested with clean cold water @ 20°C. High specific gravity versions build to order.

Zentrifugalpumpe mit Magnetkupplung Magnetically coupled centrifugal pump NEMP 120/8

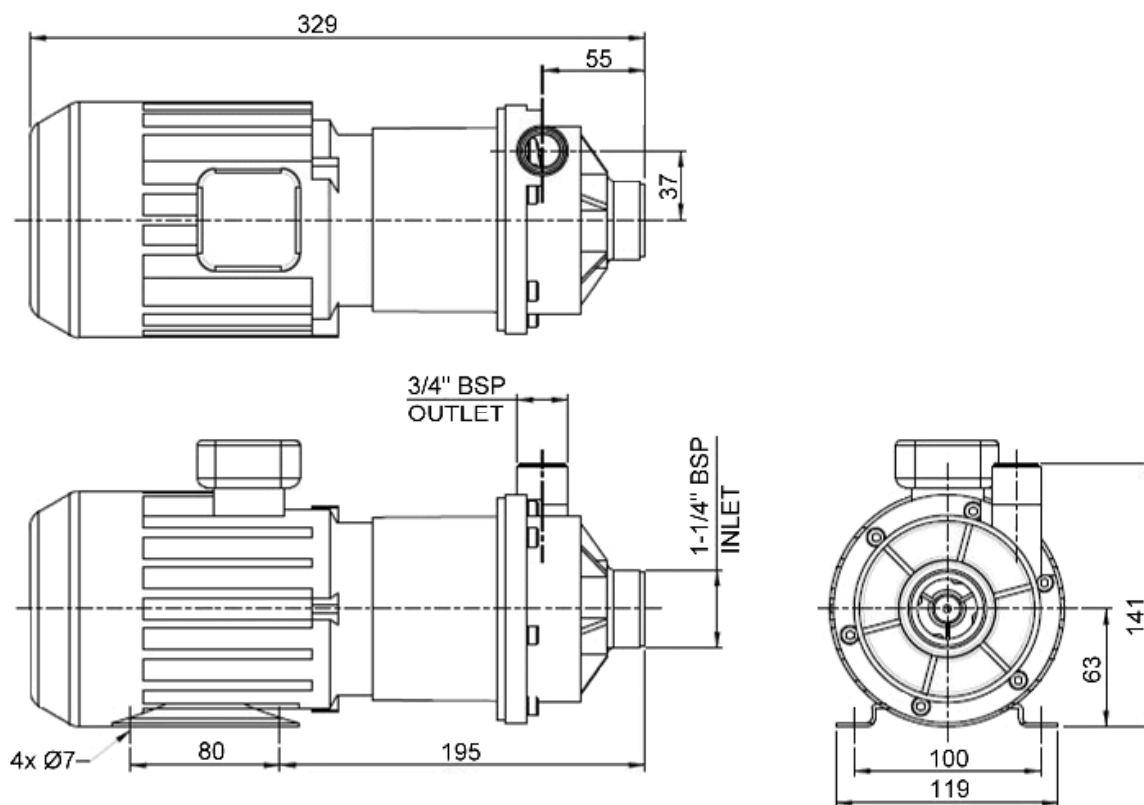

Technische Daten (Technical data) NEMP 120/8			
max. Fördermenge	(discharge rate)	117 l/min (50Hz)	
max. Förderhöhe	(delivery head)	7,2 m (50Hz)	
Temperaturbereich	(temperature range)	-20...+85°C (PP)	-20...+95°C (PPS)
max. Dichte	(max. specific gravity)	1,2 Kg/dm ³ @ max. 30 mPa s	
Gehäusedruck	(pump casing pressure)	1,7 bar	
Saugstutzen	(inlet port)	1 1/4" BSP AG (M)	
Druckstutzen	(discharge side)	3/4" BSP AG (M)	
Gehäusematerial	(pump casing material)	PP	PPS
Flügelrad	(impeller)	PP	PPS
Welle	(spindle material)	Keramik (Ceramic)	
O-Ring	(o-ring)	EPDM alternativ NBR, VITON	
Motor	(motor)	230 V, 1 Ph, 50Hz	415 V, 3 Ph, 50 Hz
Leistung	(motor capacity)	250 Watt	
Schutzart	(protection category)	IP 55	
Gesamtgewicht	(total weight)	~ 5,5 kg	

Achtung: Die Pumpen sind nicht selbstansaugend und nicht für Trockenlauf geeignet.

Attention: These magnetically pumps are designed for use with clean fluids. Solids will cause jamming. Abrasives will reduce pump live and invalidate the warranty. The pumps are not designed to run dry.

Zentrifugalpumpe mit Magnetkupplung Magnetically coupled centrifugal pump NEMP 120/8

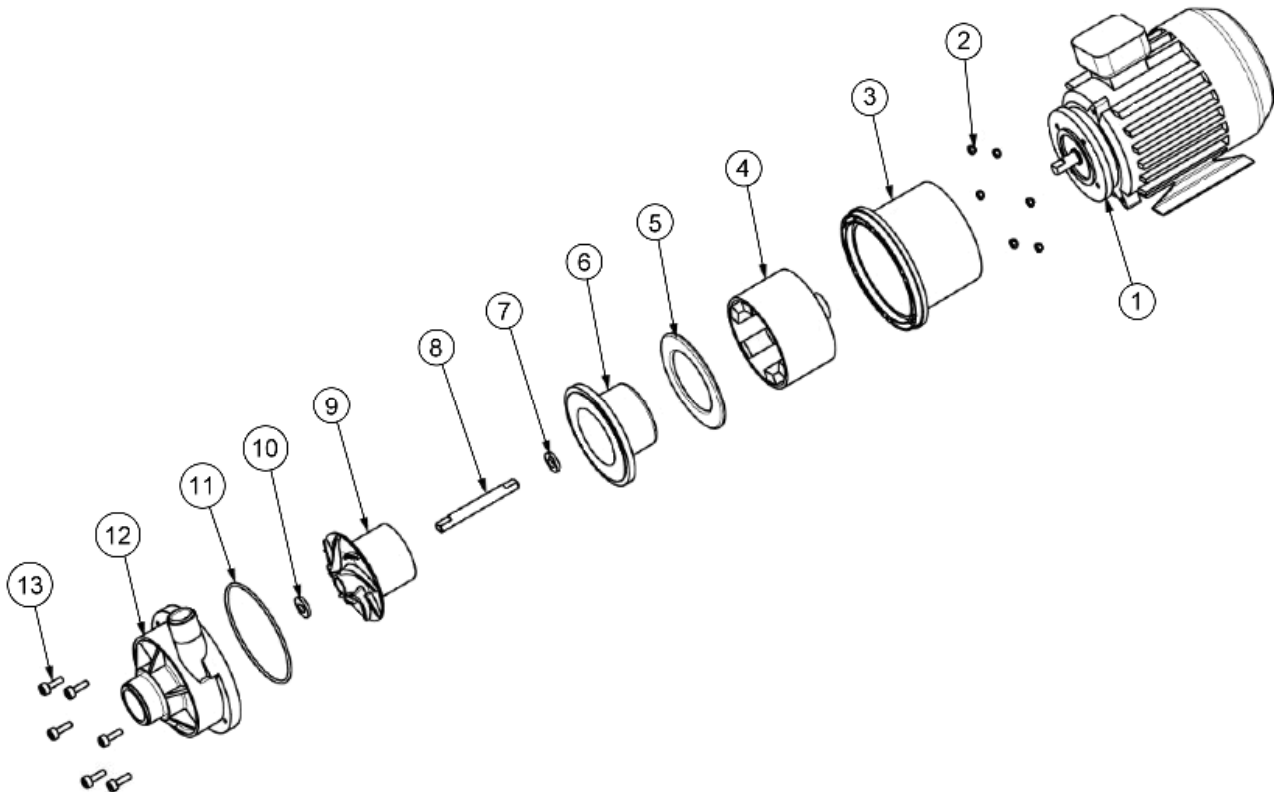

Typ	Pos.	Beschreibung	Description	Stück	Artikel-Nr.	zusätzl. Angaben
NEMP 120/8	1	Motor	Motor	1	008857	110V 1Ph 50Hz
					008843	110V 1 Ph 60Hz
					008823	230V 1Ph 50/60 Hz
					008824	400V 3Ph 50/60 Hz
NEMP 120/8	2	Mutter	Nut	6	032105	
NEMP 120/8	3	Laterne	Adaptor	1	018368	
NEMP 120/8	4	Antriebsmagnet	Drive Magnet	1	008624	
NEMP 120/8	5	Zentrierscheibe	Support Plate	1	008295	
NEMP 120/8	6	Spindelgehäuse	Spindle Housing	1	016311	PPS
					008301	PP
					008302	PVDF
NEMP 120/8	7	D-Gleitscheibe	D Washer	1	008298	
NEMP 120/8	8	Spindel	Spindle	1	008297	
NEMP 120/8	9	Flügelrad	Impeller	1	038607	50Hz PP
					018633	50Hz PVDF
					018667	60Hz/High SG PP
					018668	60Hz/High SG PVDF
NEMP 120/8	10	D-Gleitscheibe	D Washer	1	008298	
NEMP 120/8	11	O-Ring	O-Ring	1	008276	EPDM
					008217	Viton
NEMP 120/8	12	Pumpengehäuse	Pump Body	1	018382	PP
					008217	PVDF
NEMP 120/8	13	Schraube	Screw	6	022115	