

Zentrifugalpumpe mit Magnetkupplung Magnetically coupled centrifugal pump NEMP 80/6

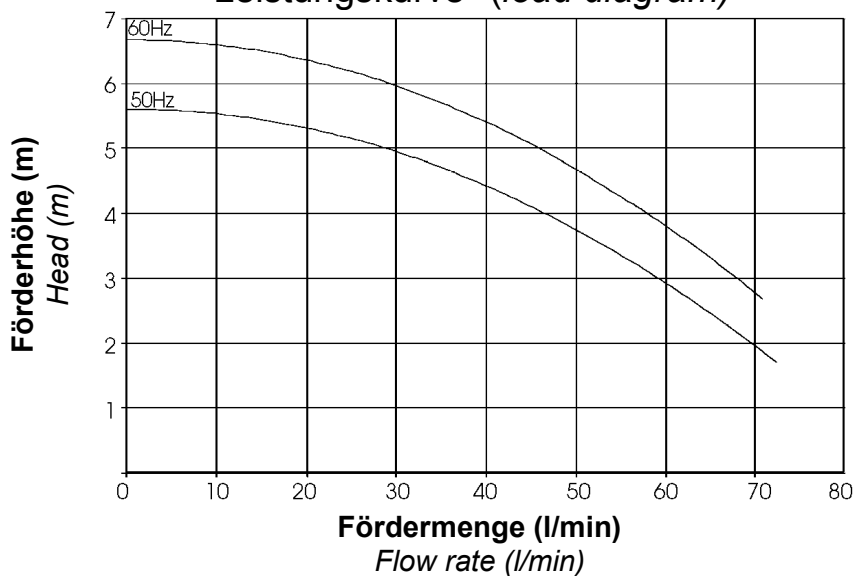

Leistungskurve* (load diagram)*



Typ Type	Volt	Ph	Hz	Saugstutzen inlet port	Druckstutzen discharge side	Artikel-Nr. PP Item number	Artikel-Nr. PPS Item number
NEMP 80/6	230	1	50	Ø 26mm glatt (plain)	Ø 26mm glatt (plain)	166919	
NEMP 80/6	230	1	50	¾" BSP AG (M)	¾" BSP AG (M)	166921	
NEMP 80/6	230	1	60	Ø 26mm glatt (plain)	Ø 26mm glatt (plain)	176926	
NEMP 80/6	230	1	60	¾" BSP AG (M)	¾" BSP AG (M)	176925	
NEMP 80/6	110	1	50	Ø 26mm glatt (plain)	Ø 26mm glatt (plain)	186917	
NEMP 80/6	110	1	50	¾" BSP AG (M)	¾" BSP AG (M)	206978	
NEMP 80/6	110	1	60	Ø 26mm glatt (plain)	Ø 26mm glatt (plain)	186916	
NEMP 80/6	110	1	60	¾" BSP AG (M)	¾" BSP AG (M)	196986	

* Die Leistungskurve wurde mit Wasser bei 20°C ermittelt

* Performance tested with clean cold water @ 20°C

Zentrifugalpumpe mit Magnetskupplung Magnetically coupled centrifugal pump NEMP 80/6

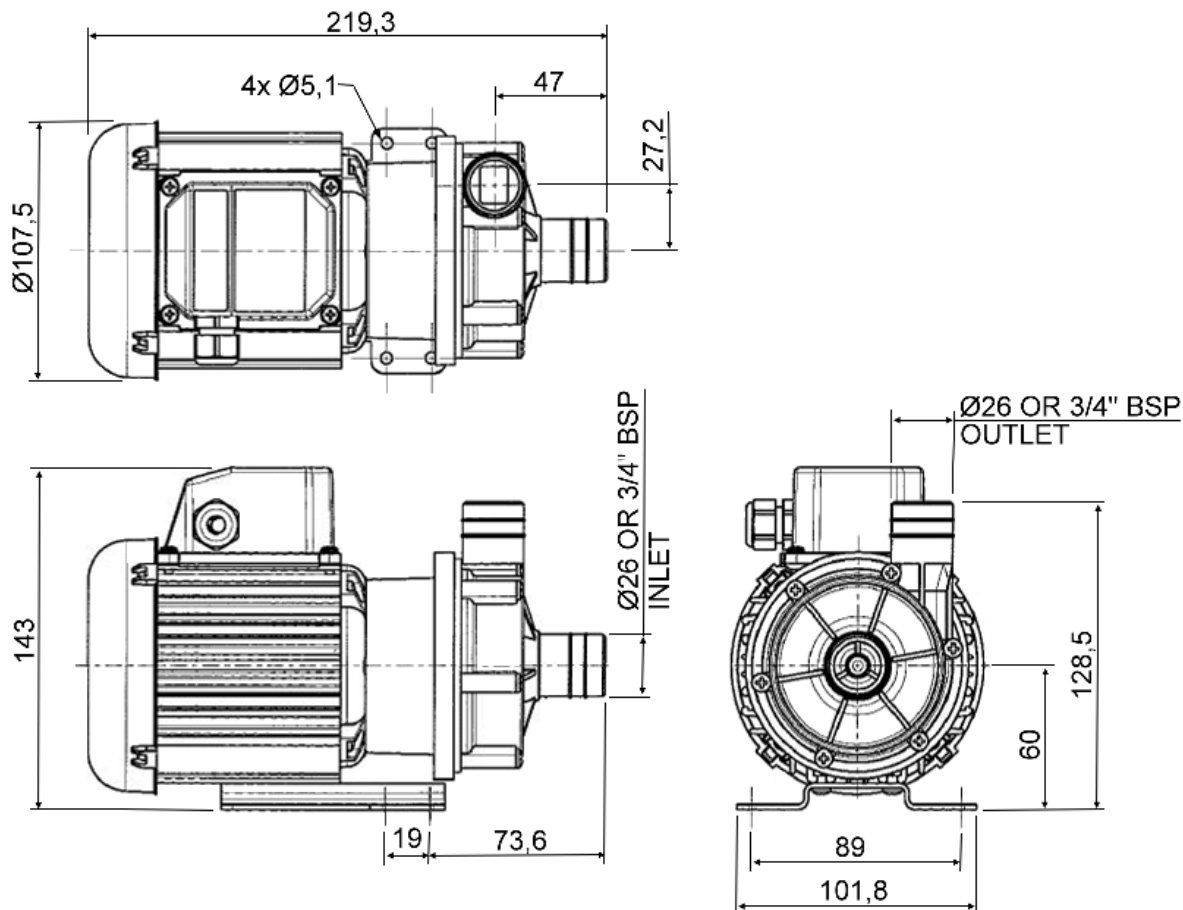

Technische Daten (Technical data) NEMP 80/6

max. Fördermenge	(discharge rate)	80 l/min (50Hz)	80 l/min (60Hz)
max. Förderhöhe	(delivery head)	5,5 m (50Hz)	5,5 m (60Hz)
Temperaturbereich	(temperature range)	-20...+85°C (PP)	-20...+95°C (PPS)
max. Dichte	(max. specific gravity)	1,2 Kg/dm ³ @ max. 30 mPa s	
Gehäusedruck	(pump casing pressure)	1,4 bar	
Saugstutzen	(inlet port)	3/4" BSP AG (M)	Ø 26 mm glatt (plain)
Druckstutzen	(discharge side)	3/4" BSP AG (M)	Ø 26 mm glatt (plain)
Gehäusematerial	(pump casing material)	PP	PPS
Flügelrad	(impeller)	PP	PPS
Welle	(spindle material)	Keramik (Ceramic)	
O-Ring	(o-ring)	EPDM alternativ NBR, VITON	
Motor	(motor)	230 V, 1 Ph, 50Hz	230 V, 1 Ph, 60 Hz
		110 V, 1 Ph, 50 Hz	110 V, 1 Ph, 60 Hz
Leistung	(motor capacity)	95 Watt	
Schutzart	(protection category)	IP X5	
Gesamtgewicht	(total weight)	~ 3,1 kg	

Achtung: Die Pumpen sind nicht selbstansaugend und nicht für Trockenlauf geeignet.

Attention: These magnetically pumps are designed for use with clean fluids. Solids will cause jamming. Abrasives will reduce pump live and invalidate the warranty. The pumps are not designed to run dry.

Zentrifugalpumpe mit Magnetkupplung Magnetically coupled centrifugal pump NEMP 80/6

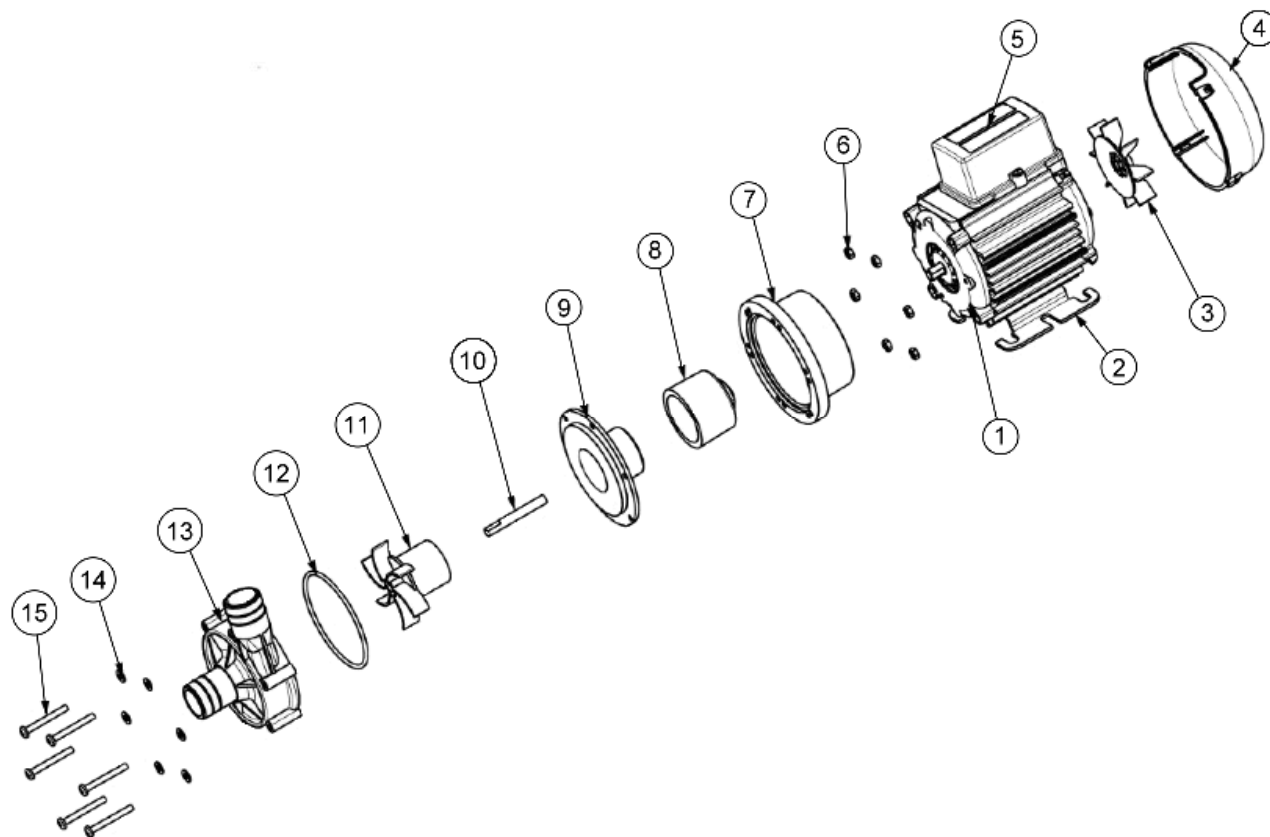

Typ	Pos.	Beschreibung	Description	Stück	Artikel-Nr.	zusätzl. Angaben
NEMP 80/6	1	Motor	Motor	1	116842	230V
					116875	110V
NEMP 80/6	2	Montagefuß	Mounting Foot	1	036329	
NEMP 80/6	3	Lüfterrad	Fan	1	001577	
NEMP 80/6	4	Lüfterabdeckung	Fan Cowl	1	036085	
NEMP 80/6	5	Anschlusskasten	Terminal Box	1	036028	
NEMP 80/6	6	Mutter	Nut	6	032105	
NEMP 80/6	7	Laterne	Adaptor	1	036324	
NEMP 80/6	8	Antriebsmagnet	Drive Magnet	1	016541	
NEMP 80/6	9	Spindelgehäuse	Spindle Housing	1	016311	
NEMP 80/6	10	Spindel	Spindle	1	006244	
NEMP 80/6	11	Flügelrad	Impeller	1	016355	50Hz
					026215	60Hz
NEMP 80/6	12	O-Ring	O-Ring	1	013290	EPDM
					021056	Viton
					003398	Nitrile
NEMP 80/6	13	Pumpengehäuse	Pump Body	1	016359	Ø 26mm PP
					016367	Ø 26mm PPS
					016361	3/4" BSP PP
					016369	3/4" BSP PPS
NEMP 80/6	14	Scheibe	Washer	6	001565	
NEMP 80/6	15	Schraube	Screw	6	022115	