

Zentrifugalpumpe mit Magnetkupplung Magnetically coupled centrifugal pump NEMP 60/6

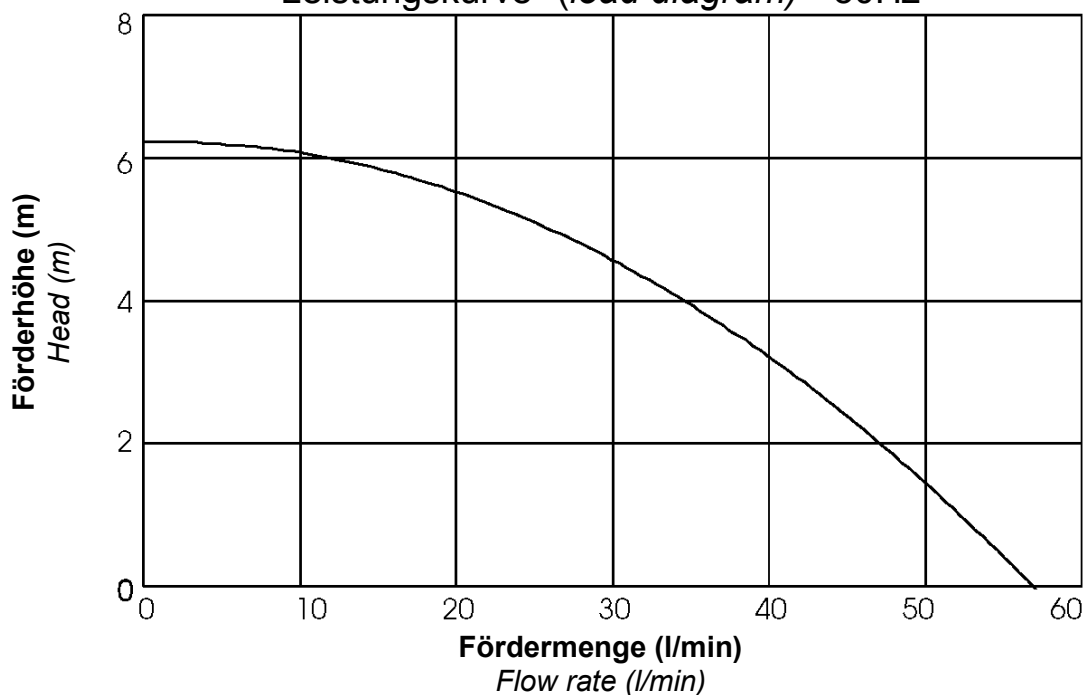

Leistungskurve* (load diagram)* 50Hz



Typ Type	Volt	Ph	Hz	Saugstutzen inlet port	Druckstutzen discharge side	Artikel-Nr. PP Item number	Artikel-Nr. PPS Item number
NEMP 60/6	415	3	50	Ø 21mm glatt (plain)	Ø 21mm glatt (plain)	018923	
NEMP 60/6	415	3	50	½" BSP AG (M)	½" BSP AG (M)	018924	

* Die Leistungskurve wurde mit Wasser bei 20°C ermittelt

* Performance tested with clean cold water @ 20°C

Zentrifugalpumpe mit Magnetkupplung Magnetically coupled centrifugal pump NEMP 60/6

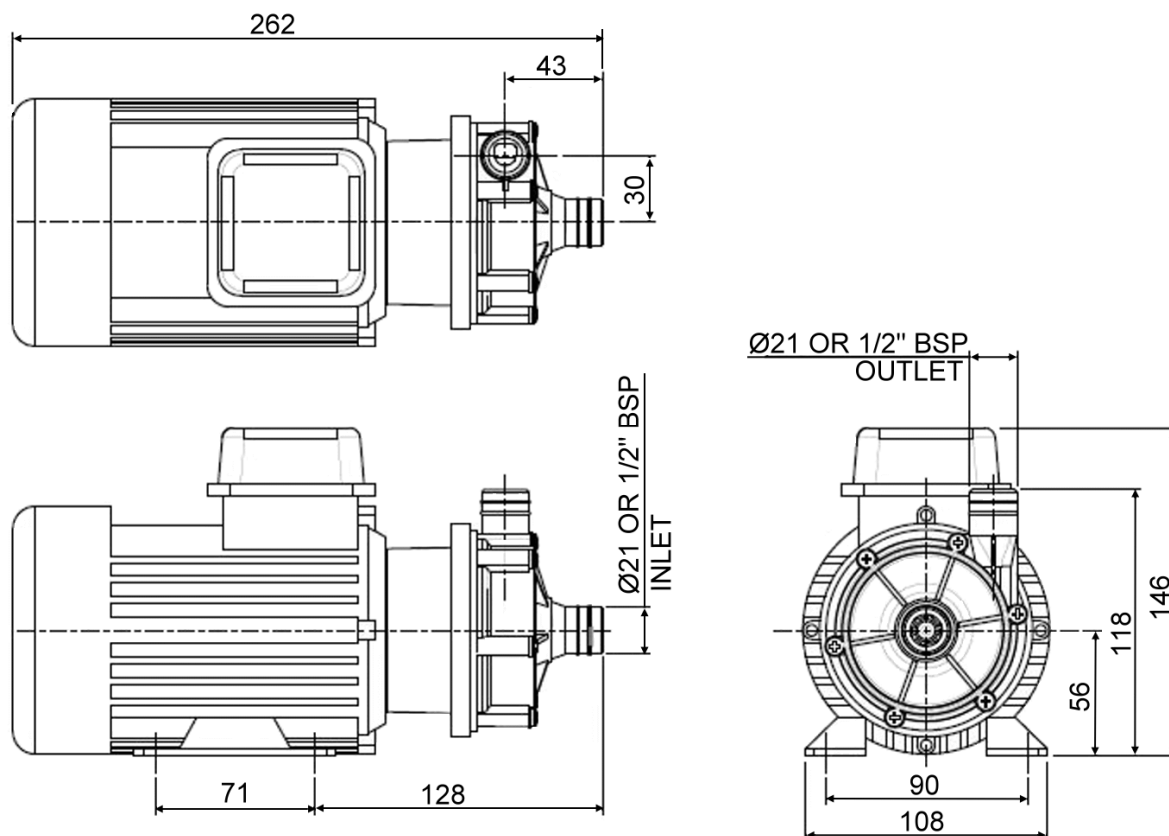

Technische Daten (Technical data) NEMP 60/6

max. Fördermenge	(discharge rate)	57 l/min (50Hz)	
max. Förderhöhe	(delivery head)	6,2 m (50Hz)	
Temperaturbereich	(temperature range)	-20...+85°C (PP)	
max. Dichte	(max. specific gravity)	1,2 Kg/dm ³ @ max. 30 mPa s	
Gehäusedruck	(pump casing pressure)	1,4 bar	
Saugstutzen	(inlet port)	1/2" BSP AG (M)	Ø 21 mm glatt (plain)
Druckstutzen	(discharge side)	1/2" BSP AG (M)	Ø 21 mm glatt (plain)
Gehäusematerial	(pump casing material)	PP	
Flügelrad	(impeller)	PP	
Welle	(spindle material)	Keramik (Ceramic)	
O-Ring	(o-ring)	EPDM alternativ NBR, VITON	
Motor	(motor)	415 V, 3 Ph, 50Hz	
Leistung	(motor capacity)	140 Watt	
Schutzart	(protection category)	IP 55	
Gesamtgewicht	(total weight)	~ 4,0 kg	

Achtung: Die Pumpen sind nicht selbstansaugend und nicht für Trockenlauf geeignet.

Attention: These magnetically pumps are designed for use with clean fluids. Solids will cause jamming. Abrasives will reduce pump live and invalidate the warranty. The pumps are not designed to run dry.

Zentrifugalpumpe mit Magnetkupplung Magnetically coupled centrifugal pump NEMP 60/6

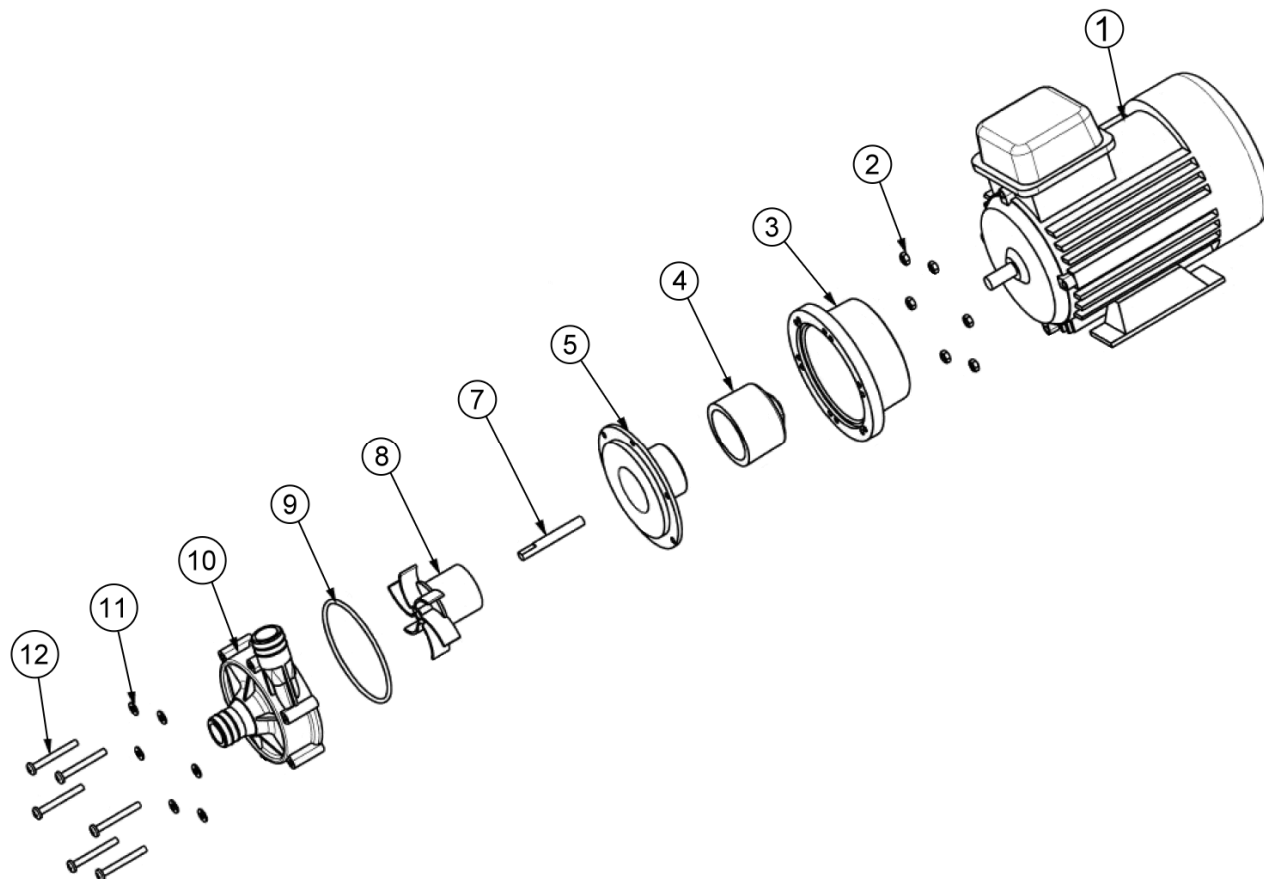

Typ	Pos.	Beschreibung	Description	Stück	Artikel-Nr.	zusätzl. Angaben
NEMP 60/6	1	Motor	Motor	1	008822	
NEMP 60/6	2	Mutter	Nut	6	032105	
NEMP 60/6	3	Laterne	Adaptor	1	002053	
NEMP 60/6	4	Antriebsmagnet	Drive Magnet	1	016541	
NEMP 60/6	5	Spindelgehäuse	Spindle Housing	1	016311	
NEMP 60/6	7	Spindel	Shaft	1	006244	
NEMP 60/6	8	Flügelrad	Impeller	1	016355	
NEMP 60/6	9	O-Ring	O-Ring	1	013290	EPDM
					021056	Viton
					003398	Nitrile
NEMP 60/6	10	Pumpengehäuse	Pump Body	1	016358	Ø 21mm PP
					016366	Ø 21mm PPS
					016360	½" BSP PP
					016368	½" BSP PPS
NEMP 60/6	11	Scheibe	Washer	6	012020	
NEMP 60/6	12	Schraube	Screw	6	022115	