

## Zentrifugalpumpe mit Magnetkupplung Magnetically coupled centrifugal pump NEMP 50/7

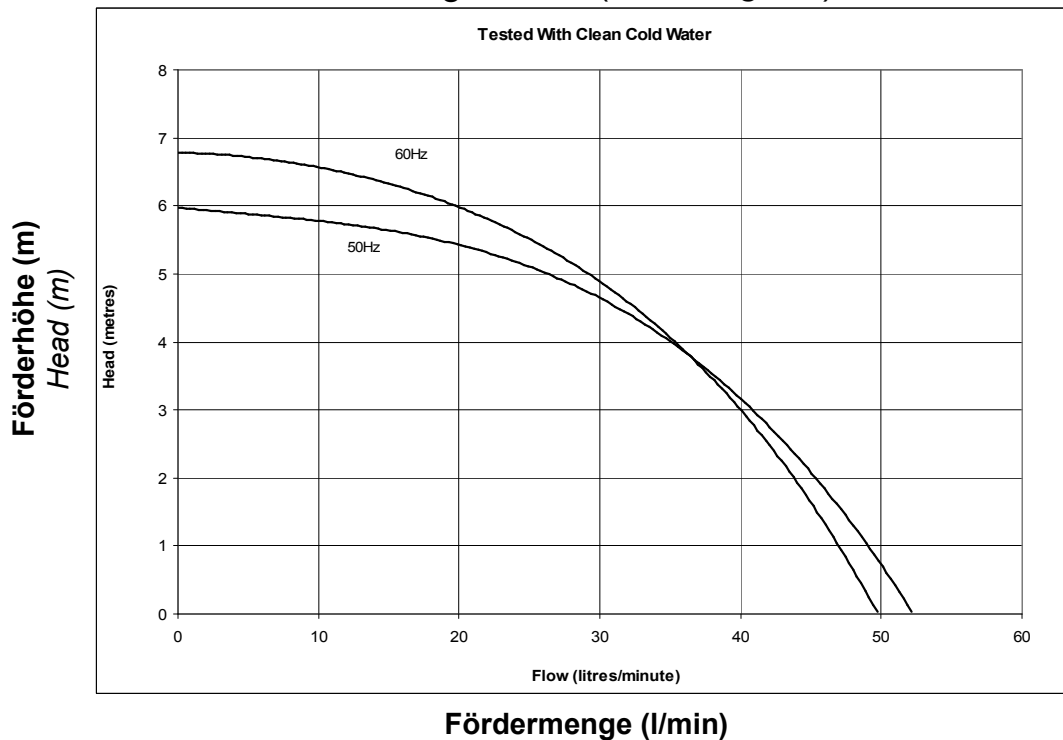

Leistungskurve\* (load diagram)\*



Typ Type	Volt	Ph	Hz	Saugstutzen inlet port	Druckstutzen discharge side	Artikel-Nr. PP Item number	Artikel-Nr. PPS Item number
NEMP 50/7	230	1	50	Ø 21mm glatt (plain)	Ø 21mm glatt (plain)	456904	
NEMP 50/7	230	1	50	½" BSP AG (M)	½" BSP AG (M)	446932	
NEMP 50/7	230	1	60	Ø 21mm glatt (plain)	Ø 21mm glatt (plain)	106926	
NEMP 50/7	230	1	60	½" BSP AG (M)	½" BSP AG (M)	116951	
NEMP 50/7	110	1	50	Ø 21mm glatt (plain)	Ø 21mm glatt (plain)	106957	
NEMP 50/7	110	1	50	½" BSP AG (M)	½" BSP AG (M)	106955	
NEMP 50/7	110	1	60	Ø 21mm glatt (plain)	Ø 21mm glatt (plain)	186914	
NEMP 50/7	110	1	60	½" BSP AG (M)	½" BSP AG (M)	216954	

\* Die Leistungskurve wurde mit Wasser bei 20°C ermittelt \* Performance tested with clean cold water @ 20°C

## Zentrifugalpumpe mit Magnetkupplung Magnetically coupled centrifugal pump NEMP 50/7

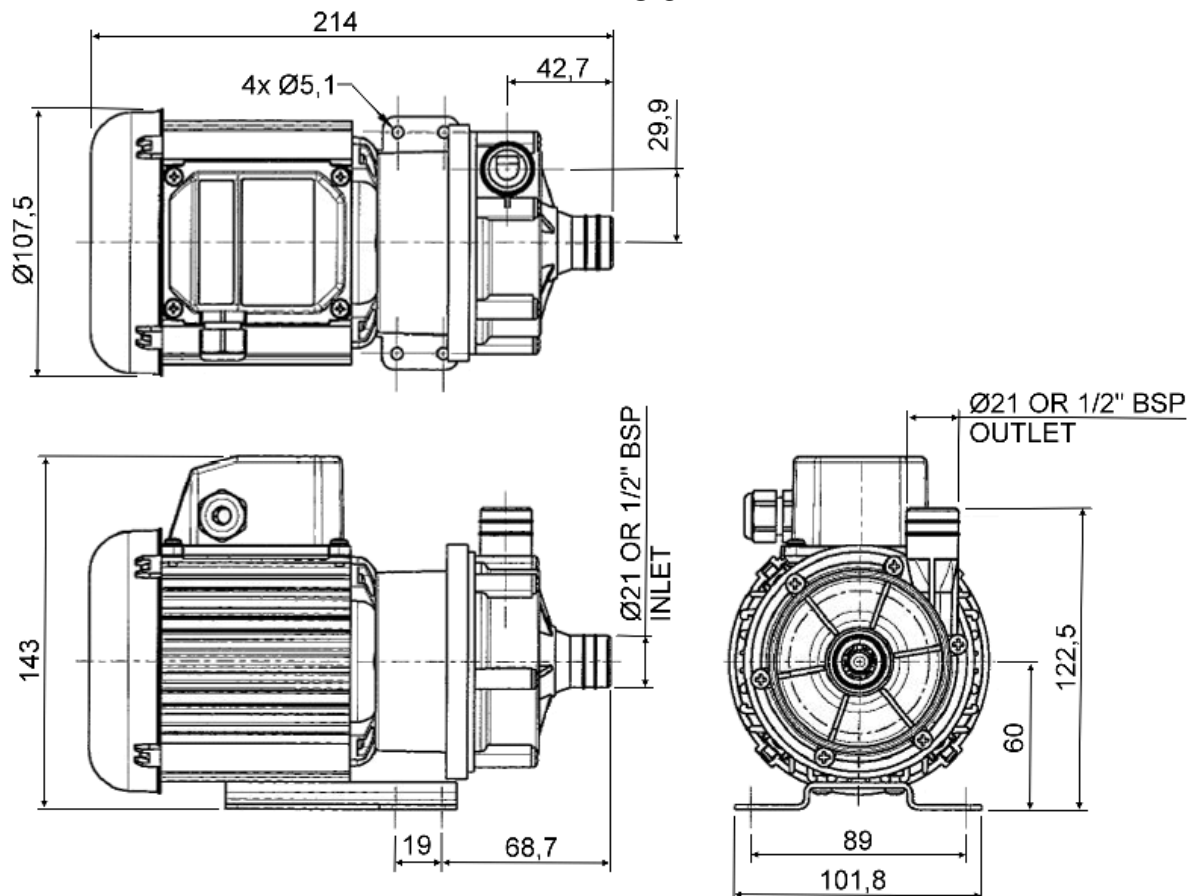

### Technische Daten (Technical data) NEMP 50/7

max. Fördermenge ( <i>discharge rate</i> )		52 l/min (50Hz)	50 l/min (60Hz)
max. Förderhöhe ( <i>delivery head</i> )		6,0 m (50Hz)	6,8 m (60Hz)
Temperaturbereich ( <i>temperature range</i> )		-20...+85°C (PP)	-20...+95°C (PPS)
max. Dichte ( <i>max. specific gravity</i> )		1,2 Kg/dm <sup>3</sup> @ max. 30 mPa s	
Gehäusedruck ( <i>pump casing pressure</i> )		1,4 bar	
Saugstutzen ( <i>inlet port</i> )		1/2" BSP AG ( <b>M</b> )	Ø 21 mm glatt ( <b>plain</b> )
Druckstutzen ( <i>discharge side</i> )		1/2" BSP AG ( <b>M</b> )	Ø 21 mm glatt ( <b>plain</b> )
Gehäusematerial ( <i>pump casing material</i> )		PP	PPS
Flügelrad ( <i>impeller</i> )		PP	PPS
Welle ( <i>spindle material</i> )		Keramik ( <b>Ceramic</b> )	
O-Ring ( <i>o-ring</i> )		EPDM alternativ NBR, VITON	
Motor ( <i>motor</i> )		230 V, 1 Ph, 50Hz	230 V, 1 Ph, 60 Hz
Leistung ( <i>motor capacity</i> )		110 V, 1 Ph, 50 Hz	110 V, 1 Ph, 60 Hz
Schutzart ( <i>protection category</i> )		95 Watt	
Gesamtgewicht ( <i>total weight</i> )		IP X5	
		~ 3,0 kg	

**Achtung:** Die Pumpen sind nicht selbstansaugend und nicht für Trockenlauf geeignet.

**Attention:** These magnetically pumps are designed for use with clean fluids. Solids will cause jamming. Abrasives will reduce pump live and invalidate the warranty. The pumps are not designed to run dry.

## Zentrifugalpumpe mit Magnetkupplung

*Magnetically coupled centrifugal pump*

### NEMP 50/7

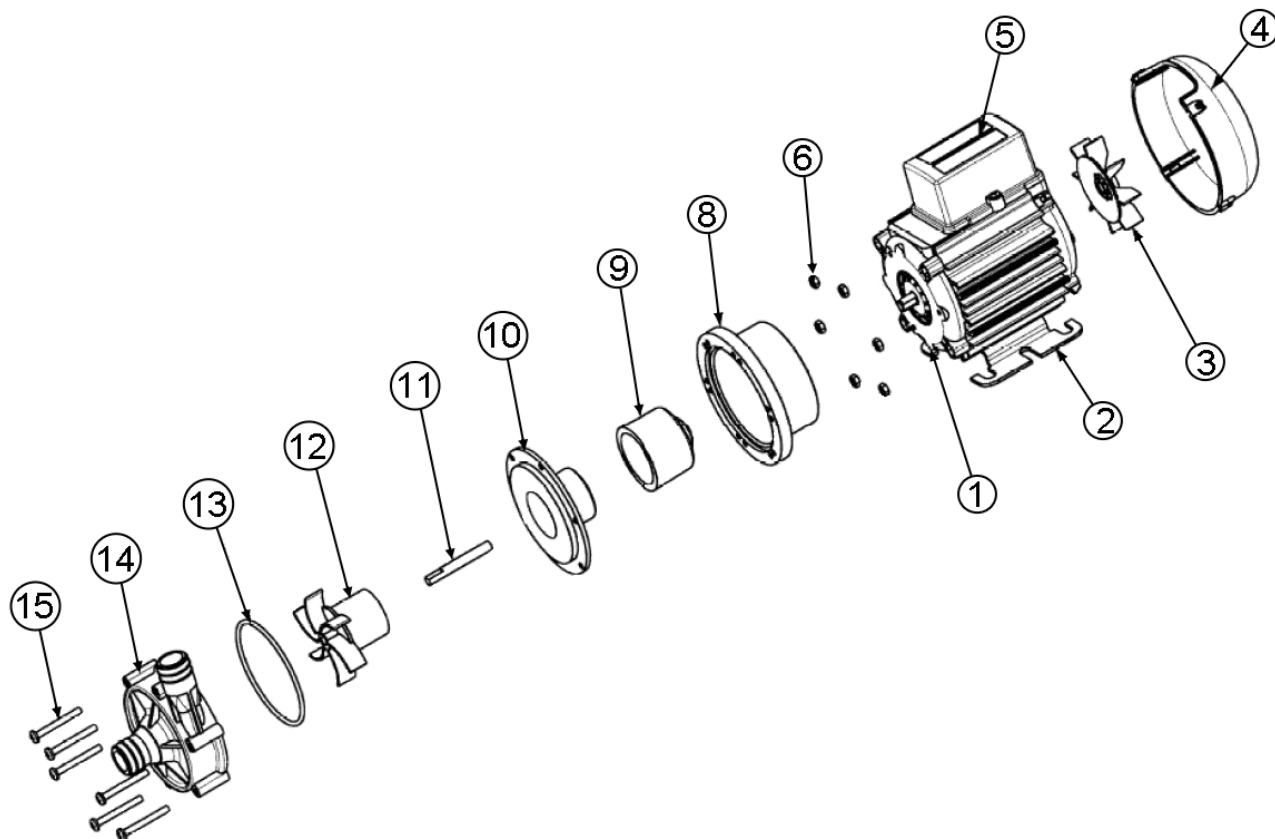

Typ	Pos.	Beschreibung	Description	Stück	Artikel-Nr.	zusätzl. Angaben
NEMP 50/7	1	Motor	<i>Motor</i>	1	116842	230 V
					116875	110 V
NEMP 50/7	2	Montagefuß	<i>Mounting Foot</i>	1	036329	
NEMP 50/7	3	Lüfterrad	<i>Fan</i>	1	001577	
NEMP 50/7	4	Lüfterabdeckung	<i>Fan Cowl</i>	1	036085	
NEMP 50/7	5	Anschlusskasten	<i>Terminal Box</i>	1	036028	
NEMP 50/7	6	Mutter	<i>Nut</i>	6	032105	
NEMP 50/7	8	Laterne	<i>Adaptor</i>	1	036324	
NEMP 50/7	9	Antriebsmagnet	<i>Drive Magnet</i>	1	006287	
NEMP 50/7	10	Spindelgehäuse	<i>Spindle Housing</i>	1	016311	
NEMP 50/7	11	Spindel	<i>Spindle</i>	1	006244	Standard
					036347	99,5% Al
NEMP 50/7	12	Flügelrad	<i>Impeller</i>	1	016355	50Hz
					026215	60Hz
NEMP 50/7	13	O-Ring	<i>O-Ring</i>	1	013290	EPDM
					021056	Viton
					003398	Nitrile
NEMP 50/7	14	Pumpengehäuse	<i>Pump Body</i>	1	016358	Ø 21mm PP
					016366	Ø 21mm PPS
					016360	1/2" BSP PP
					016368	1/2" BSP PPS
NEMP 50/7	15	Schraube	<i>Screw</i>	6	022115	