

Zentrifugalpumpe mit Magnetkupplung Magnetically coupled centrifugal pump GP 40/6

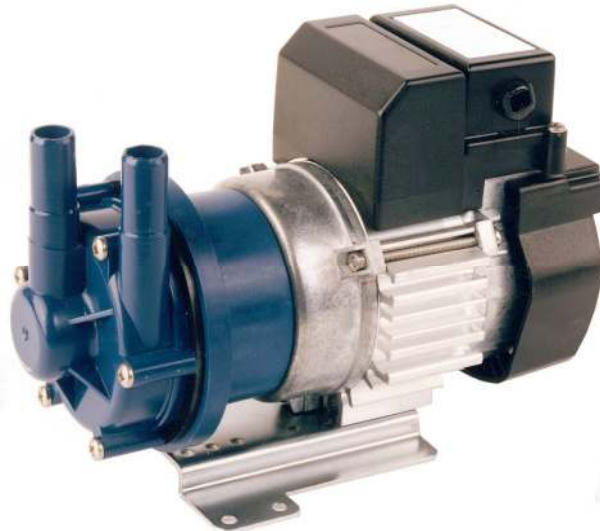

Leistungskurve*

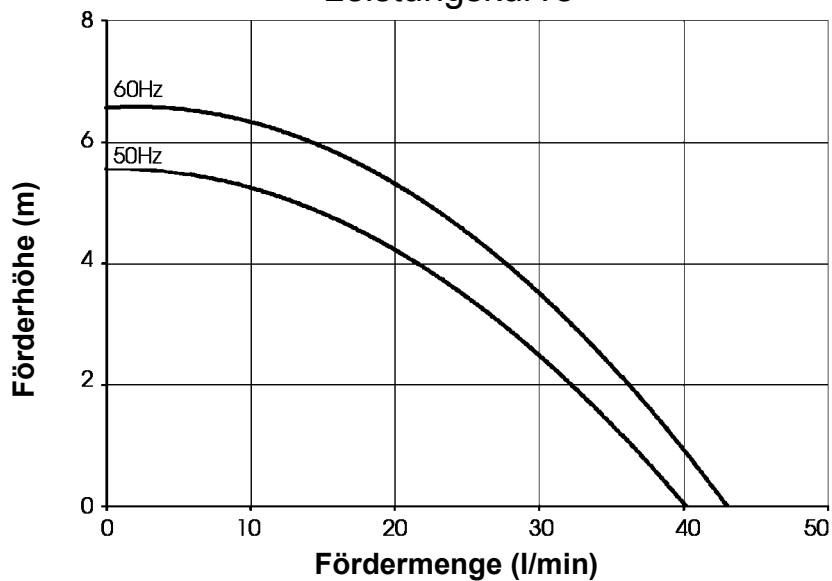

Typ	Volt	Ph	Hz	Saugstutzen	Druckstutzen	Artikel-Nr. PP	Artikel-Nr. PPS
GP 40/6	230	1	50	Ø 15mm glatt	Ø 15mm glatt	146998	
GP 40/6	230	1	50	3/8" BSP AG	3/8" BSP AG	176946	
GP 40/6	230	1	60	Ø 15mm glatt	Ø 15mm glatt		
GP 40/6	230	1	60	3/8" BSP AG	3/8" BSP AG		
GP 40/6	110	1	50	Ø 15mm glatt	Ø 15mm glatt		
GP 40/6	110	1	50	3/8" BSP AG	3/8" BSP AG		
GP 40/6	110	1	60	Ø 15mm glatt	Ø 15mm glatt		
GP 40/6	110	1	60	3/8" BSP AG	3/8" BSP AG		

* Die Leistungskurve wurde mit Wasser bei 20°C ermittelt

* Performance tested with clean cold water @ 20°C

Zentrifugalpumpe mit Magnetkupplung Magnetically coupled centrifugal pump GP 40/6

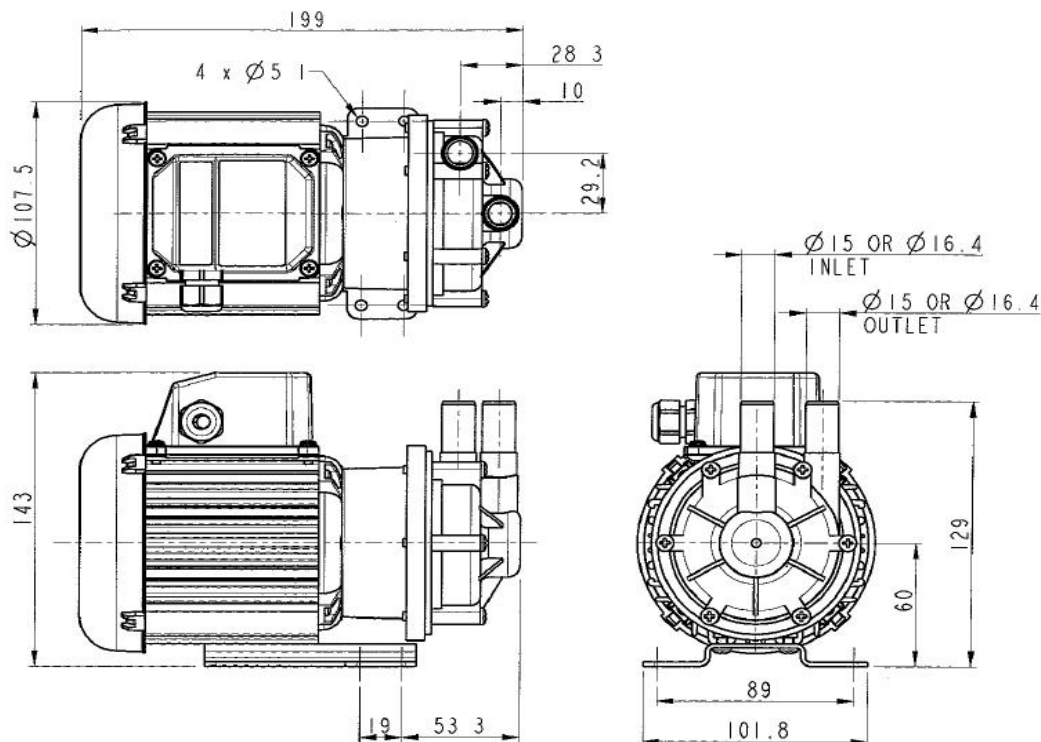

Technische Daten (Technical data)

max. Fördermenge	(discharge rate)	40 l/min (50Hz)	43 l/min (60Hz)
max. Förderhöhe	(delivery head)	5,6 m (50Hz)	6,6 m (60Hz)
Temperaturbereich	(temperature range)	-20...+85°C (PP)	
max. Dichte	(max. specific gravity)	1,2 Kg/dm ³ @ max. 30cp Viskosität	
Gehäusedruck	(pump casing pressure)	1,4 bar	
Saugstutzen	(inlet port)	3/8" BSP AG	Ø 15mm glatt plain
Druckstutzen	(discharge side)	3/8" BSP AG	Ø 15mm glatt plain
Gehäusematerial	(pump casing material)	PP	
Flügelrad	(impeller)	PP	
Welle	(spindle material)	Messing (Brass)	
O-Ring	(o-ring)	NBR (Nitrile)	
Gleitscheibe	(thrust washer)	Keramik (Alumina ceramic)	
Motor	(motor)	230 V, 1 Ph, 50 Hz	110 V, 1 Ph, 50 Hz
		230 V, 1 Ph, 60 Hz	110 V, 1 Ph, 60 Hz
Leistung	(motor capacity)	60 Watt	
Schutzart	(protection category)	IP X5	
Gesamtgewicht	(total weight)	~ 2,7 kg	

Achtung: Die Pumpen sind nicht selbstansaugend und nicht für Trockenlauf geeignet.

Attention: These magnetically pumps are designed for use with clean fluids. Solids will cause jamming. Abrasives will reduce pump live and invalidate the warranty. The pumps are not designed to run dry.

Zentrifugalpumpe mit Magnetkupplung Magnetically coupled centrifugal pump GP 40/6

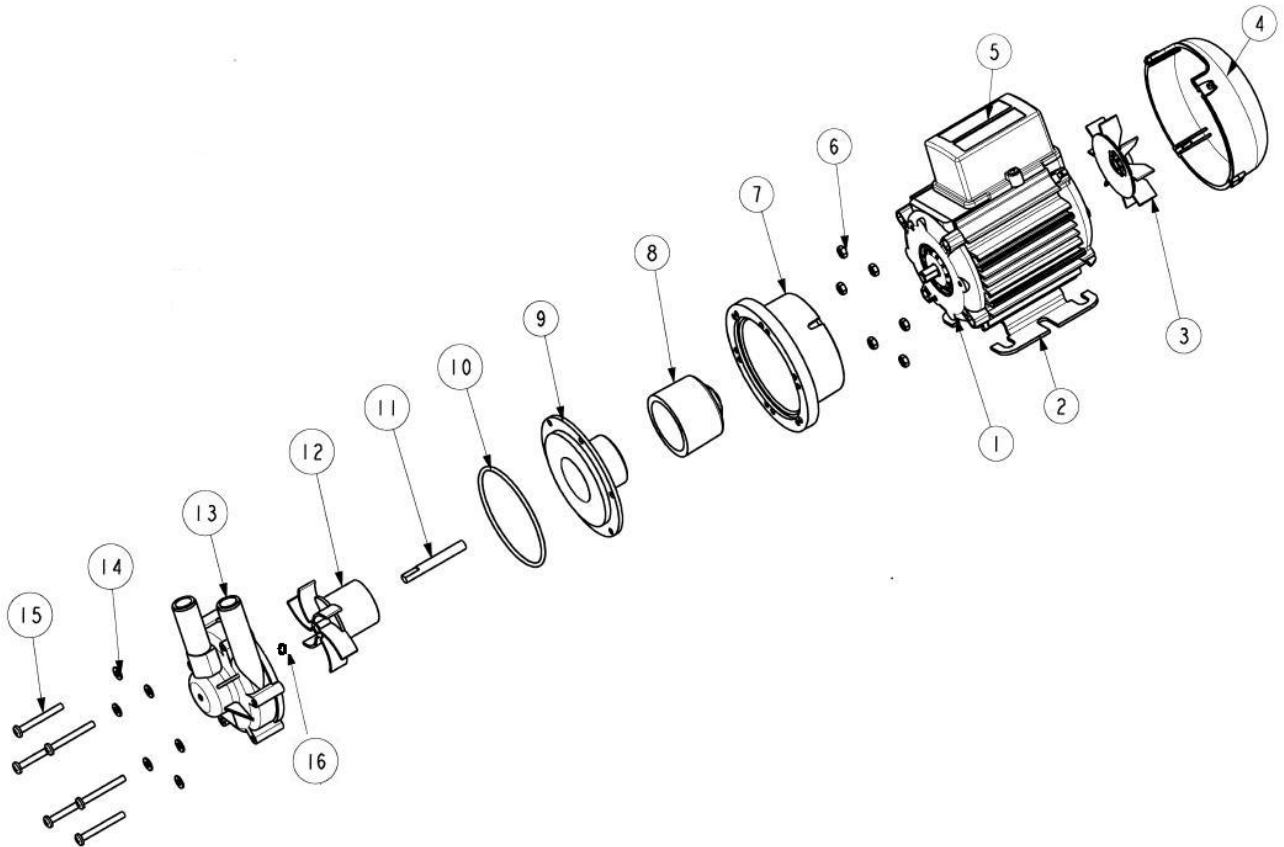

Typ	Pos.	Beschreibung	Description	Stück	Artikel-Nr.	zusätzl. Angaben
GP 40/6	1	Motor	Motor	1	116842	230 V
					116875	110 V
GP 40/6	2	Montagefuß	Mounting Foot	1	036329	
GP 40/6	3	Lüfterrad	Fan	1	001577	
GP 40/6	4	Lüfterabdeckung	Fan Cowl	1	036085	
GP 40/6	5	Anschlusskasten	Terminal Box	1	036078	
GP 40/6	6	Mutter	Nut	6	032105	
GP 40/6	7	Laterne	Adaptor	1	036324	
GP 40/6	8	Antriebsmagnet	Drive Magnet	1	006287	
GP 40/6	9	Spindelgehäuse	Spindle Housing	1	016311	
GP 40/6	10	O-Ring	O-Ring	1	003398	
GP 40/6	11	Spindel	Spindle	1	016301	
GP 40/6	12	Flügelrad	Impeller	1	016267	50Hz
					016282	60Hz
GP 40/6	13	Pumpengehäuse	Pump Body	1	016303	plain
					036354	threaded
GP 40/6	14	Mutter	Nut	6	032105	
GP 40/6	15	Schraube	Screw	6	022115	
GP 40/6	16	Gleitscheibe	D Washer	1	016225	