

## Mehrstufige Zentrifugalpumpe mit Magnetkupplung Magnetically coupled centrifugal pump GP 20/12

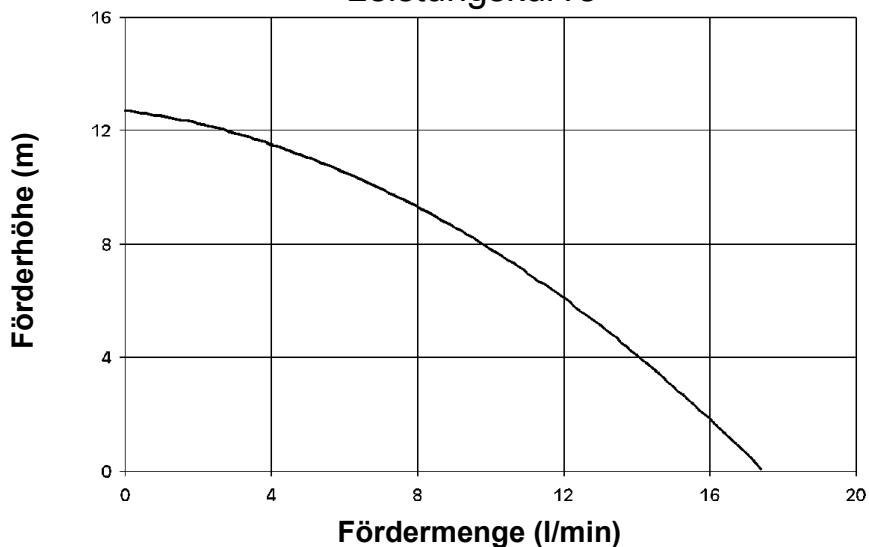

Leistungskurve\*



Typ	Volt	Ph	Hz	Saugstutzen	Druckstutzen	Artikel-Nr. PP	Artikel-Nr. PPS
GP 20/12	230	1	50	Ø 15mm glatt	Ø 15mm glatt		176922
GP 20/12	230	1	50	3/8" BSP AG	3/8" BSP AG		166927
GP 20/12	230	1	60	Ø 15mm glatt	Ø 15mm glatt		186944
GP 20/12	230	1	60	3/8" BSP AG	3/8" BSP AG		
GP 20/12	110	1	50	Ø 15mm glatt	Ø 15mm glatt		176975
GP 20/12	110	1	50	3/8" BSP AG	3/8" BSP AG		196971
GP 20/12	110	1	60	Ø 15mm glatt	Ø 15mm glatt		186900
GP 20/12	110	1	60	3/8" BSP AG	3/8" BSP AG		

\* Die Leistungskurve wurde mit Wasser bei 20°C ermittelt

\* Performance tested with clean cold water @ 20°C

## Mehrstufige Zentrifugalpumpe mit Magnetkupplung Magnetically coupled centrifugal pump GP 20/12

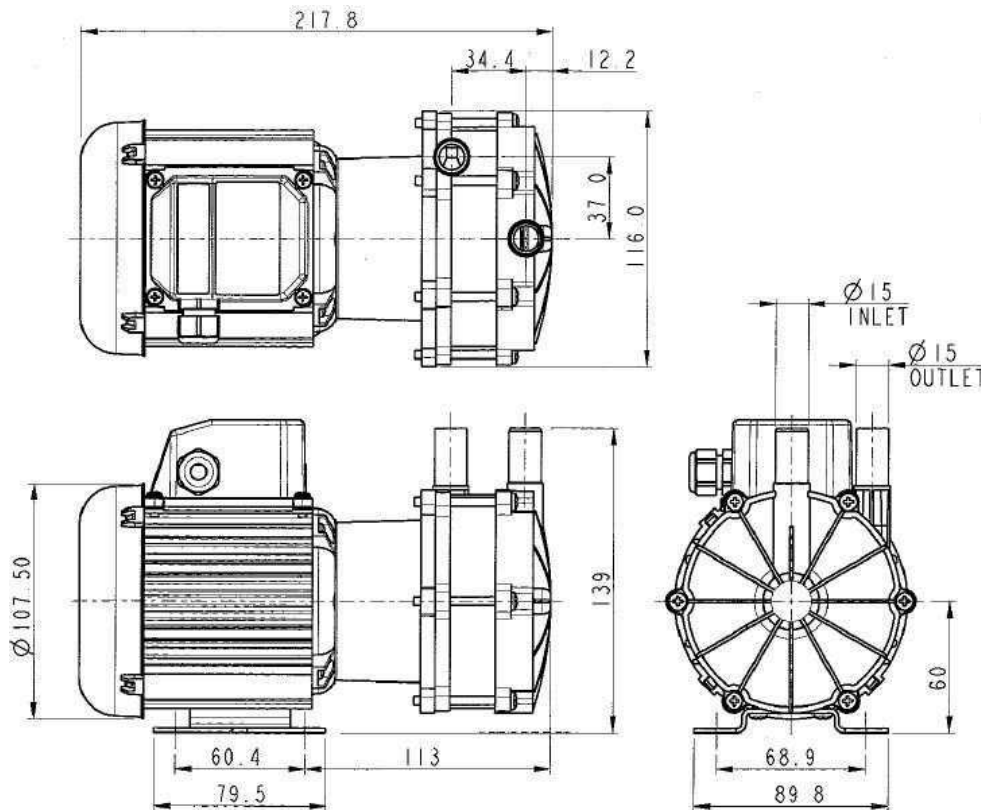

### Technische Daten (Technical data)

max. Fördermenge	<b>(discharge rate)</b>	17,4 l/min (50Hz)	
max. Förderhöhe	<b>(delivery head)</b>	12,7 m (50Hz)	
Temperaturbereich	<b>(temperature range)</b>	-20...+85°C (PP)	
max. Dichte	<b>(max. specific gravity)</b>	1,2 Kg/dm <sup>3</sup> @ max. 30cp Viskosität	
Gehäusedruck	<b>(pump casing pressure)</b>	2,5 bar	
Saugstutzen	<b>(inlet port)</b>	3/8" BSP AG	Ø 15mm glatt <b>plain</b>
Druckstutzen	<b>(discharge side)</b>	3/8" BSP AG	Ø 15mm glatt <b>plain</b>
Gehäusematerial	<b>(pump casing material)</b>	PP	PPS
Flügelrad	<b>(impeller)</b>	PP	PPS
Welle	<b>(spindle material)</b>	Messing ( <b>Brass</b> )	
O-Ring	<b>(o-ring)</b>	NBR	
Gleitscheibe	<b>(thrust washer)</b>	Keramik/Graphit/PTFE ( <b>Ceramic/Graphite/PTFE</b> )	
Motor	<b>(motor)</b>	230 V, 1 Ph, 50 Hz	110 V, 1 Ph, 50 Hz
Leistung	<b>(motor capacity)</b>	60 Watt ( <b>Output</b> )	
Schutzart	<b>(protection category)</b>	IP X5	
Gesamtgewicht	<b>(total weight)</b>	~ 2,8 kg	

**Achtung:** Die Pumpen sind nicht selbstansaugend und nicht für Trockenlauf geeignet.

**Attention:** These magnetically pumps are designed for use with clean fluids. Solids will cause jamming. Abrasives will reduce pump live and invalidate the warranty. The pumps are not designed to run dry.

## Mehrstufige Zentrifugalpumpe mit Magnetkupplung Magnetically coupled centrifugal pump GP 20/12

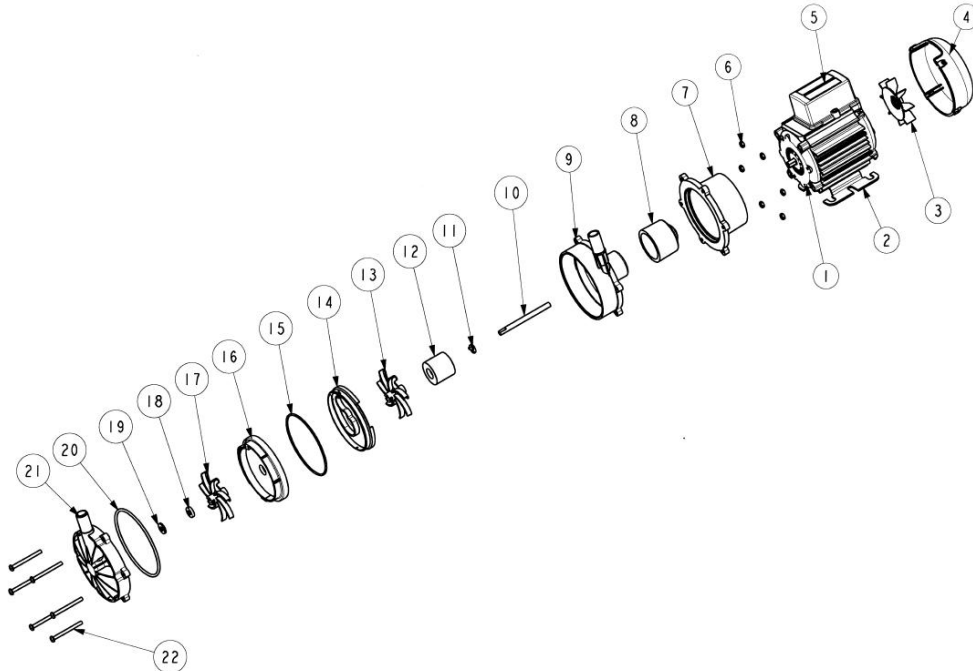

Typ	Pos.	Beschreibung	Description	Stück	Artikel-Nr.	zusätzl. Angaben
GP 20/12	1	Motor	<i>Motor</i>	1	116842	230 V
					116875	110 V
GP 20/12	2	Montagefuß	<i>Mounting Foot</i>	1	036330	
GP 20/12	3	Lüfterrad	<i>Fan</i>	1	001577	
GP 20/12	4	Lüfterabdeckung	<i>Fan Cowl</i>	1	036085	
GP 20/12	5	Anschlusskasten	<i>Terminal Box</i>	1	036078	
GP 20/12	6	Mutter	<i>Nut</i>	6	032105	
GP 20/12	7	Laterne	<i>Adaptor</i>	1	026217	
GP 20/12	8	Antriebsmagnet	<i>Drive Magnet</i>	1	006287	
GP 20/12	9	Pumpengehäuse	<i>Pump Body</i>	1	016374	threaded
					016371	plain
GP 20/12	10	Spindel	<i>Spindle</i>	1	026206	
GP 20/12	11	Druckscheibe	<i>Thrust Washer</i>	1	026208	
GP 20/12	12	Antriebsmagnet	<i>Driven Magnet</i>	1	026232	
GP 20/12	13	Flügelrad	<i>Impeller</i>	1	026238	
GP 20/12	14	Zwischenstufe	<i>Inter Stage</i>	1	026224	
GP 20/12	15	O-Ring	<i>O-Ring</i>	1	022054	
GP 20/12	16	Stufenelement	<i>Stage Element</i>	1	026223	
GP 20/12	17	Flügelrad	<i>Impeller</i>	1	026238	
GP 20/12	18	Druckscheibe	<i>Thrust Washer</i>	1	026249	
GP 20/12	19	Druckscheibe Keramik	<i>Ceramic Washer</i>	1	026252	
GP 20/12	20	O-Ring	<i>O-Ring</i>	1	022057	
GP 20/12	21	Pumpendeckel	<i>Front Cover</i>	1	026235	threaded
					026225	plain
GP 20/12	22	Schraube	<i>Screw</i>	6	022060	