

Zentrifugalpumpe mit Magnetkupplung Magnetically coupled centrifugal pump NDP 35/3

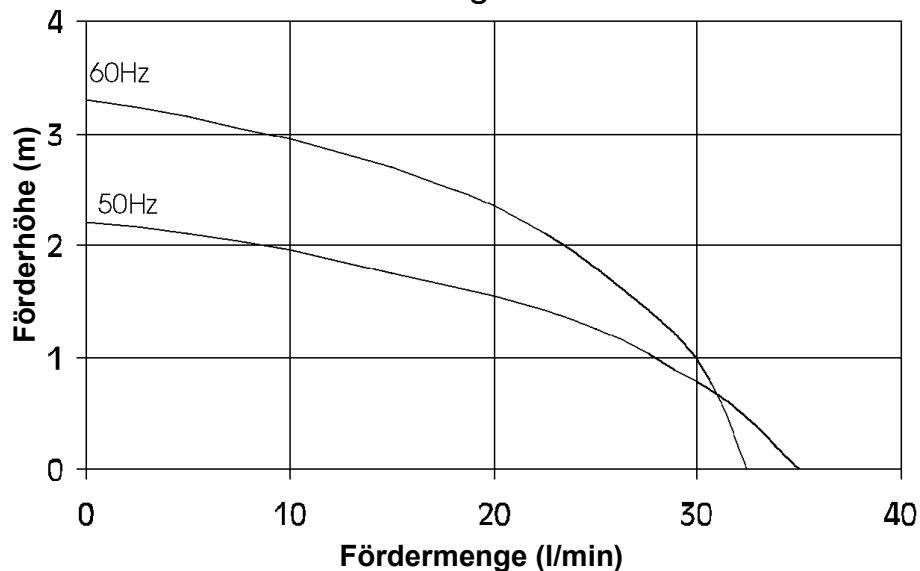

Leistungskurve*



Typ	Volt AC	Ph	Hz	Saugstutzen	Druckstutzen	Artikel-Nr. PP	Artikel-Nr. PPS
NDP 35/3	230	1	50	Ø 22mm glatt	Ø 22mm glatt	123928	
NDP 35/3	230	1	50	Ø 22mm glatt	Ø 22mm glatt	143904	mit Viton O-Ring
NDP 35/3	230	1	50	½" BSP AG	½" BSP AG	133933	
NDP 35/3	230	1	60	Ø 22mm glatt	Ø 22mm glatt	033932	
NDP 35/3	230	1	50/60	½" BSP AG	½" BSP AG	133933	
NDP 35/3	110	1	50-60	Ø 22mm glatt	Ø 22mm glatt	033935	
NDP 35/3	110	1	50-60	½" BSP AG	½" BSP AG	033934	
NDP 35/3	24	1	50	Ø 22mm glatt	Ø 22mm glatt		
NDP 35/3	24	1	50	½" BSP AG	½" BSP AG		

* Die Leistungskurve wurde mit Wasser bei 20°C ermittelt

* Performance tested with clean cold water @ 20°C

Zentrifugalpumpe mit Magnetkupplung

Magnetically coupled centrifugal pump

NDP 35/3

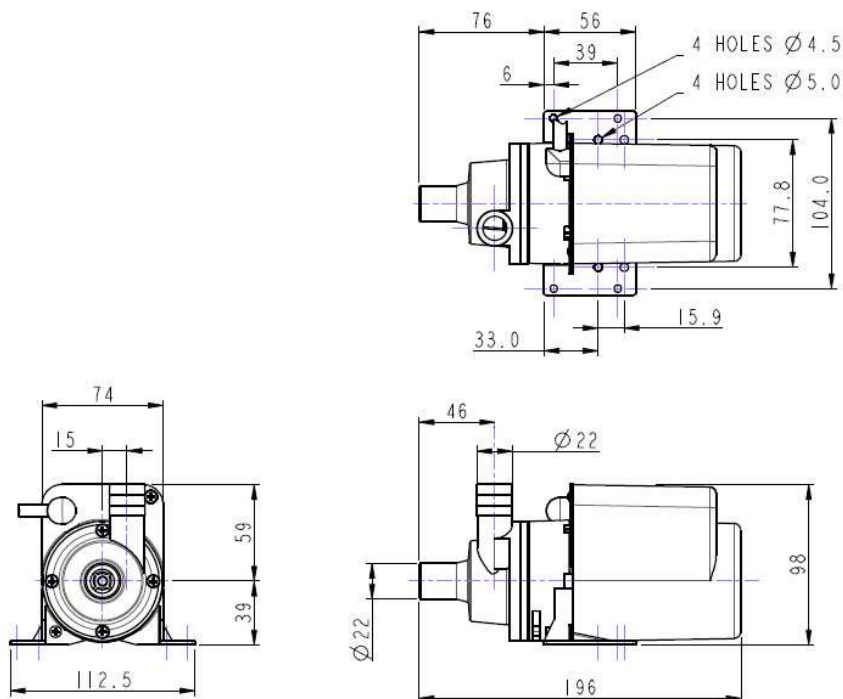

Technische Daten (Technical data) NDP 35/3

max. Fördermenge	(discharge rate)	35 l/min (50Hz)	33 l/min (60Hz)
max. Förderhöhe	(delivery head)	2,2 m (50Hz)	3,3 m (60Hz)
Temperaturbereich	(temperature range)	-20...+85°C (PP) -20...+95°C (PPS)	
max. Dichte	(max. specific gravity)	1,0 Kg/dm ³ @ max. 30 mPa s	
Gehäusedruck	(pump casing pressure)	1,4 bar	
Saugstutzen	(inlet port)	½" BSP AG	Ø 22 mm glatt (plain)
Druckstutzen	(discharge side)	½" BSP AG	Ø 22 mm glatt (plain)
Gehäusematerial	(pump casing material)	PP	PPS
Flügelrad	(impeller)	PP	PPS
Welle	(spindle material)	Keramik (Alumina ceramic)	
O-Ring	(o-ring)	EPDM alternativ NBR, VITON	
Motor	(motor)	230 V, 1 Ph, 50-60 Hz	110 V, 1 Ph, 50-60 Hz
Leistung	(motor capacity)	84 Watt (Input) / 18 Watt (Output)	
Schutzart	(protection category)	IP 22	
Gesamtgewicht	(total weight)	~ 2,3 kg	

Achtung: Die Pumpen sind nicht selbstansaugend und nicht für Trockenlauf geeignet.

Attention: These magnetically pumps are designed for use with clean fluids. Solids will cause jamming. Abrasives will reduce pump live and invalidate the warranty. The pumps are not designed to run dry.

Zentrifugalpumpe mit Magnetkupplung Magnetically coupled centrifugal pump NDP 35/3

Einzelteile:

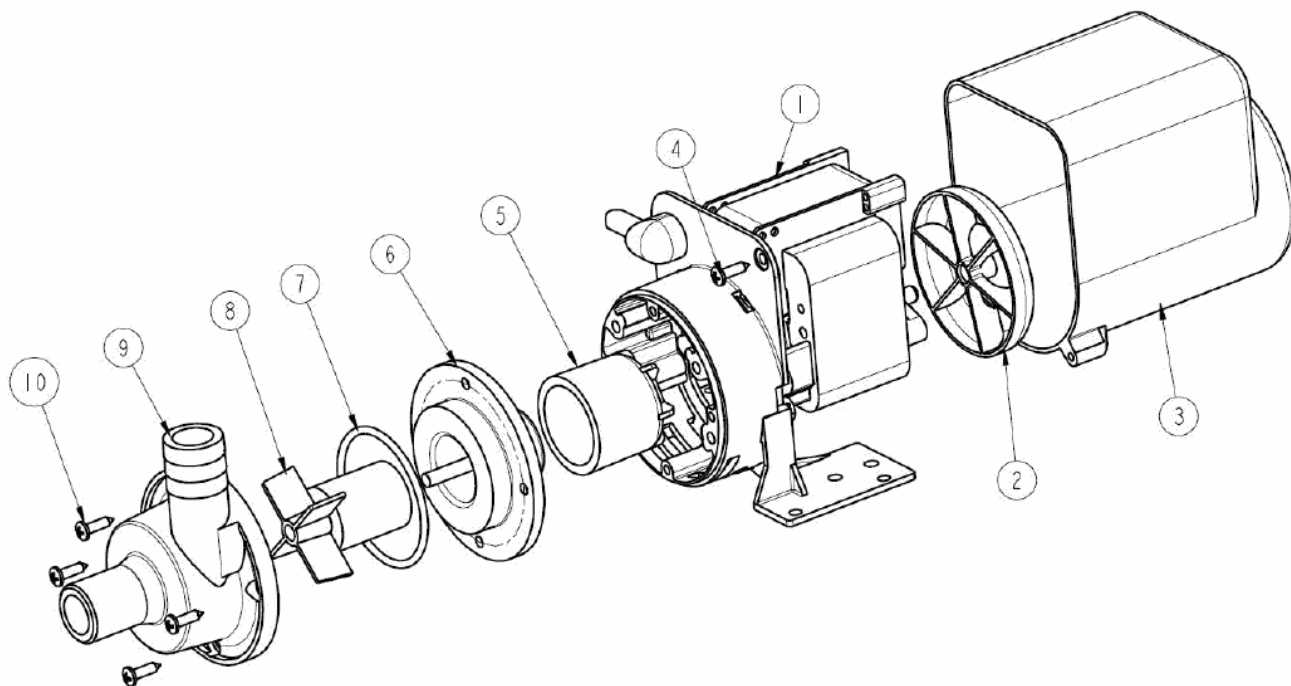

Typ	Pos.	Beschreibung		Stück	Artikel-Nr.	Ausführung
Type	Item no	Description		Quantity	Part no.	Version
NDP 35/3	1	Motor	Motor	1	-	
NDP 35/3	2	Lüfterrad	Fan	1	033322	
NDP 35/3	3	Motorgehäuse	Motor Cover	1	043335	
NDP 35/3	4	Schraube	Screw	2	001739	
NDP 35/3	5	Antriebsmagnet	Drive Magnet	1	023267	
NDP 35/3	6	Spindelgehäuse	Spindle Housing	1	003271	
NDP 35/3	7	O-Ring	O-ring	1	013291	EPDM
					003265	Viton
					003224	Nitrile
NDP 35/3	8	Flügelrad	Impeller	1	013341	
NDP 35/3	9	Pumpengehäuse	Pump Body	1	013333	Ø 22mm PP
					013334	1/2" BSP/PP
					033225	1/2" BSP/PPS
NDP 35/3	10	Schraube	Screw	4	001095	