

Zentrifugalpumpe mit Magnetkupplung *Magnetically coupled centrifugal pump* **NEMP 800/30**

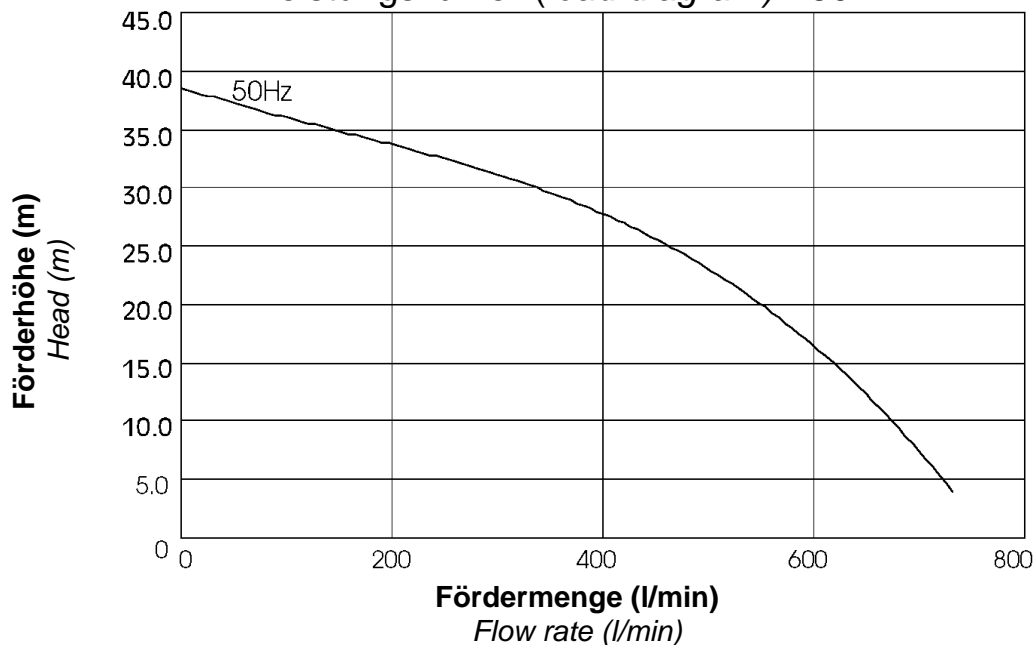

Leistungskurve* (load diagram)* 50Hz



Typ Type	Volt	Ph	Hz	Saugstutzen inlet port 75mm Flansch 75mm Flange	Druckstutzen discharge side 63mm Flansch 63mm Flange	Artikel-Nr. PP Item number	Artikel-Nr. PVDF Item number
NEMP 800/30	415	3	50			048910	048911

* Die Leistungskurve wurde mit Wasser bei 20°C ermittelt. Pumpenausführung für hohe Dichte möglich

* Performance tested with clean cold water @ 20°C. High specific gravity versions build to order.

Zentrifugalpumpe mit Magnetkupplung Magnetically coupled centrifugal pump NEMP 800/30

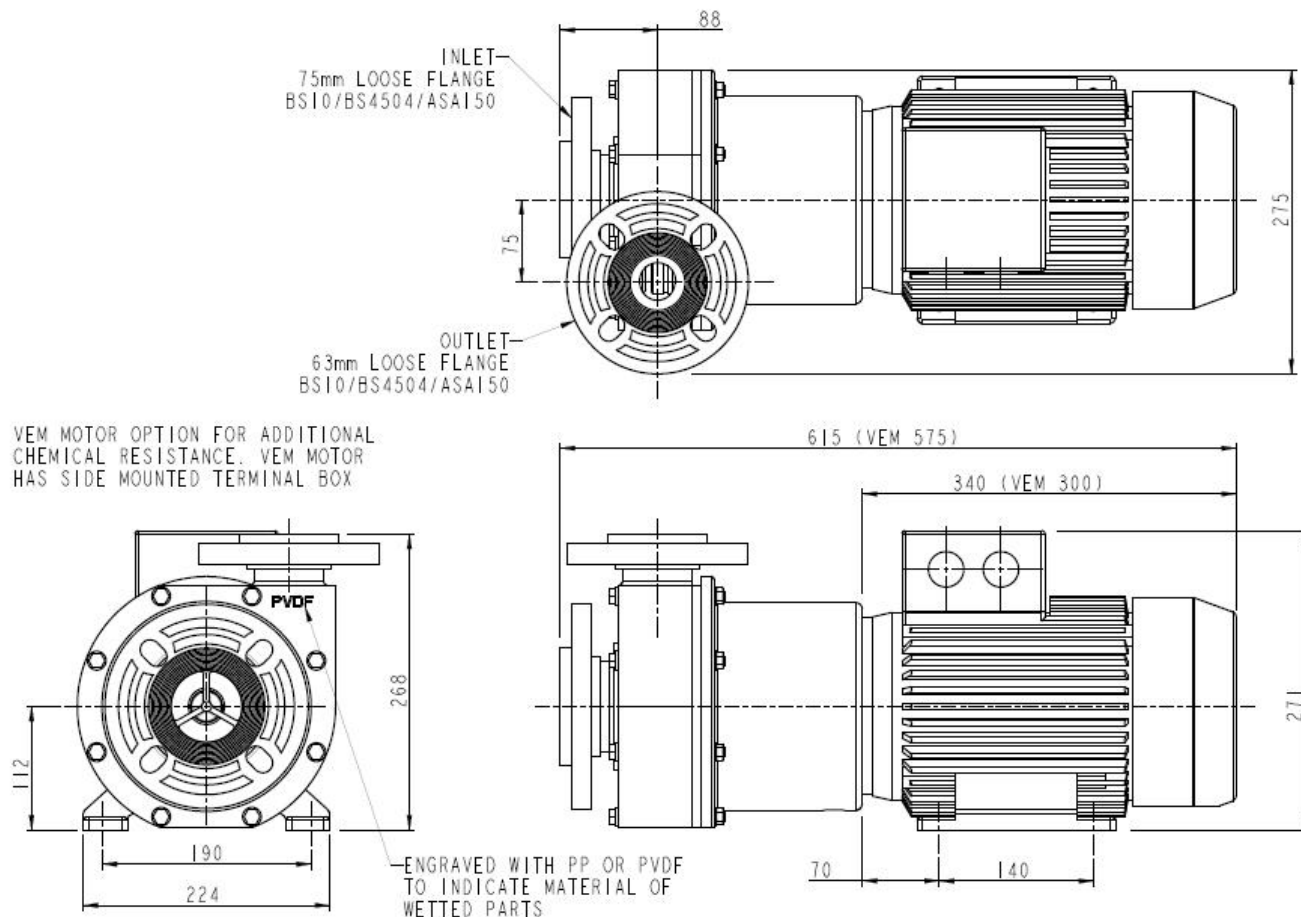

Technische Daten (Technical data) NEMP 800/30

max. Fördermenge	(discharge rate)	830 l/min (50Hz)	
max. Förderhöhe	(delivery head)	37 m (50Hz)	
Temperaturbereich	(temperature range)	-20...+85°C (PP)	-20...+95°C (PVDF)
max. Dichte	(max. specific gravity)	1,2 Kg/dm ³ @ max. 30 mPa s	
Gehäusedruck	(pump casing pressure)	3,0 bar	
Saugstutzen	(inlet port)	75 mm loser Flansch (Flange) BS10/BS4504/ASA150	
Druckstutzen	(discharge side)	63 mm loser Flansch (Flange) BS10/BS4504/ASA150	
Gehäusematerial	(pump casing material)	PP	PVDF
Flügelrad	(impeller)	PP	PVDF
Welle	(spindle material)	Keramik (Ceramic)	
O-Ring	(o-ring)	EPDM (PP), VITON (PVDF)	
Motor	(motor)	415 V, 3 Ph, 50 Hz	
Leistung	(motor capacity)	4,0 kW	
Schutzart	(protection category)	IP 55	
Gesamtgewicht	(total weight)	~ 43 kg	

Achtung: Die Pumpen sind nicht selbstansaugend und nicht für Trockenlauf geeignet.

Attention: These magnetically pumps are designed for use with clean fluids. Solids will cause jamming. Abrasives will reduce pump live and invalidate the warranty. The pumps are not designed to run dry.

Zentrifugalpumpe mit Magnetkupplung Magnetically coupled centrifugal pump NEMP 800/30

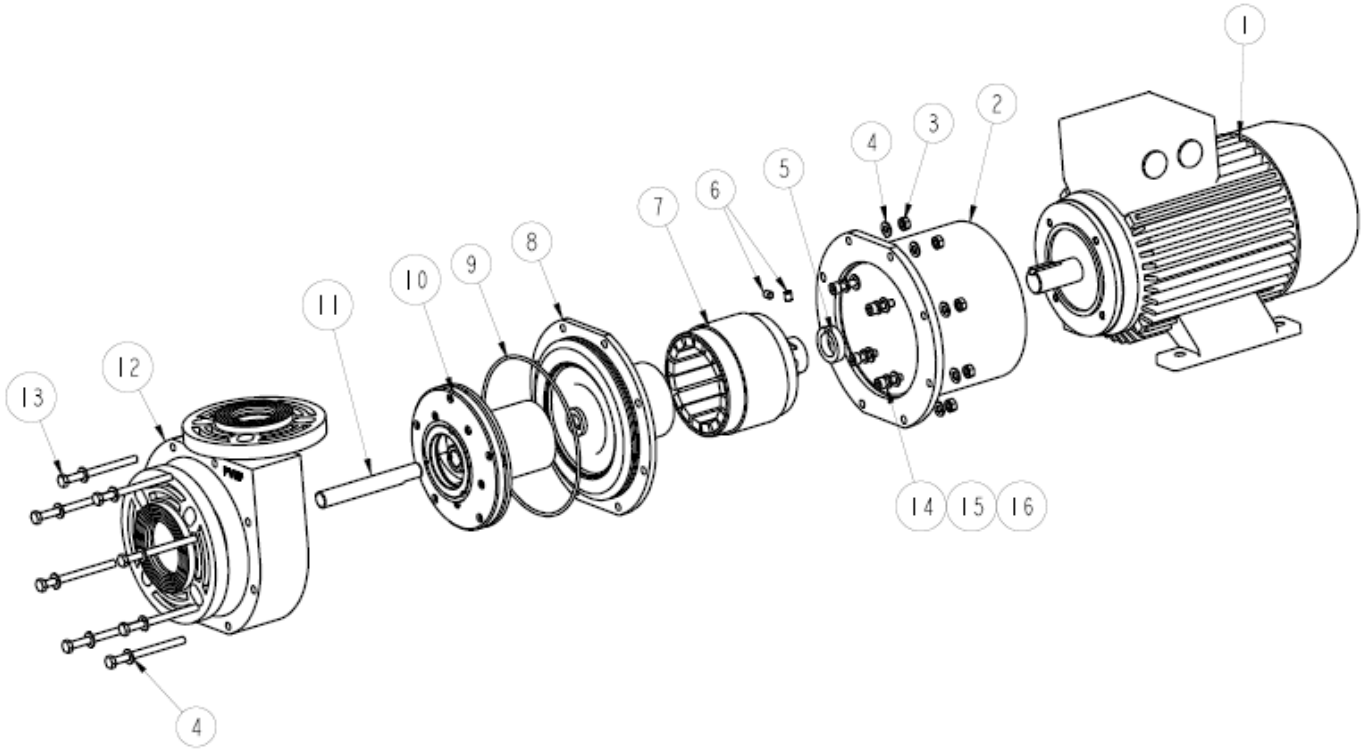

Typ	Pos.	Beschreibung	Description	Stück	Artikel-Nr.	zusätzl. Angaben
NEMP 800/30	1	Motor	Motor	1	008869	400 V 3Ph 50Hz
NEMP 800/30	2	Laterne	Adaptor	1	018348	
NEMP 800/30	3	Mutter	Nut	8	022324	
NEMP 800/30	4	Scheibe	Washer	16	001575	
NEMP 800/30	5	Distanzring	Spacer	1	028316	
NEMP 800/30	6	Gewindestift	Grub Screw	2	001685	
NEMP 800/30	7	Antriebsmagnet	Drive Magnet	1	028686	
NEMP 800/30	8	Spindelgehäuse	Spindle Housing Assy	1	038637 038639	PP/PPS PVDF
NEMP 800/30	9	O-Ring	O-Ring	1	031388 031139	EPDM Viton
NEMP 800/30	10	Flügelrad	Impeller	1	038614 038628 038635	50Hz 60Hz High SG
NEMP 800/30	11	Spindel	Spindle	1	018346	
NEMP 800/30	12	Pumpengehäuse	Pump Body	1	038622 038623	PP PVDF
NEMP 800/30	13	Schraube	Bolt	8	022404	
NEMP 800/30	14	Schraube	Bolt	4	031111	
NEMP 800/30	15	Scheibe	Washer	4	031110	
NEMP 800/30	16	Scheibe	Washer	4	001575	