

Zentrifugalpumpe mit Magnetkupplung Magnetically coupled centrifugal pump NEMP 500/20

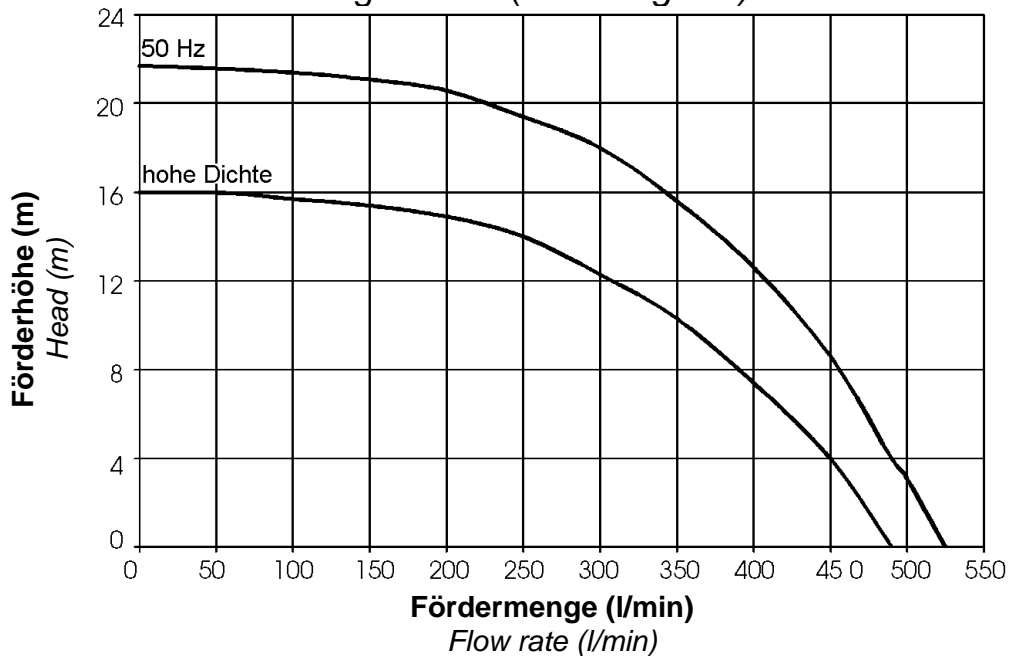

Leistungskurve* (load diagram)* 50Hz



Typ Type	Volt	Ph	Hz	Saugstutzen inlet port	Druckstutzen discharge side	Artikel-Nr. PP Item number	Artikel-Nr. PVDF Item number
NEMP 500/20	415	3	50	2" BSP AG (M)	1 1/4" BSP AG (M)	028995	028996

* Die Leistungskurve wurde mit Wasser bei 20°C ermittelt. Ausführung für hohe Dichte möglich

* Performance tested with clean cold water @ 20°C. High specific gravity versions build to order.

Zentrifugalpumpe mit Magnetkupplung Magnetically coupled centrifugal pump NEMP 500/20

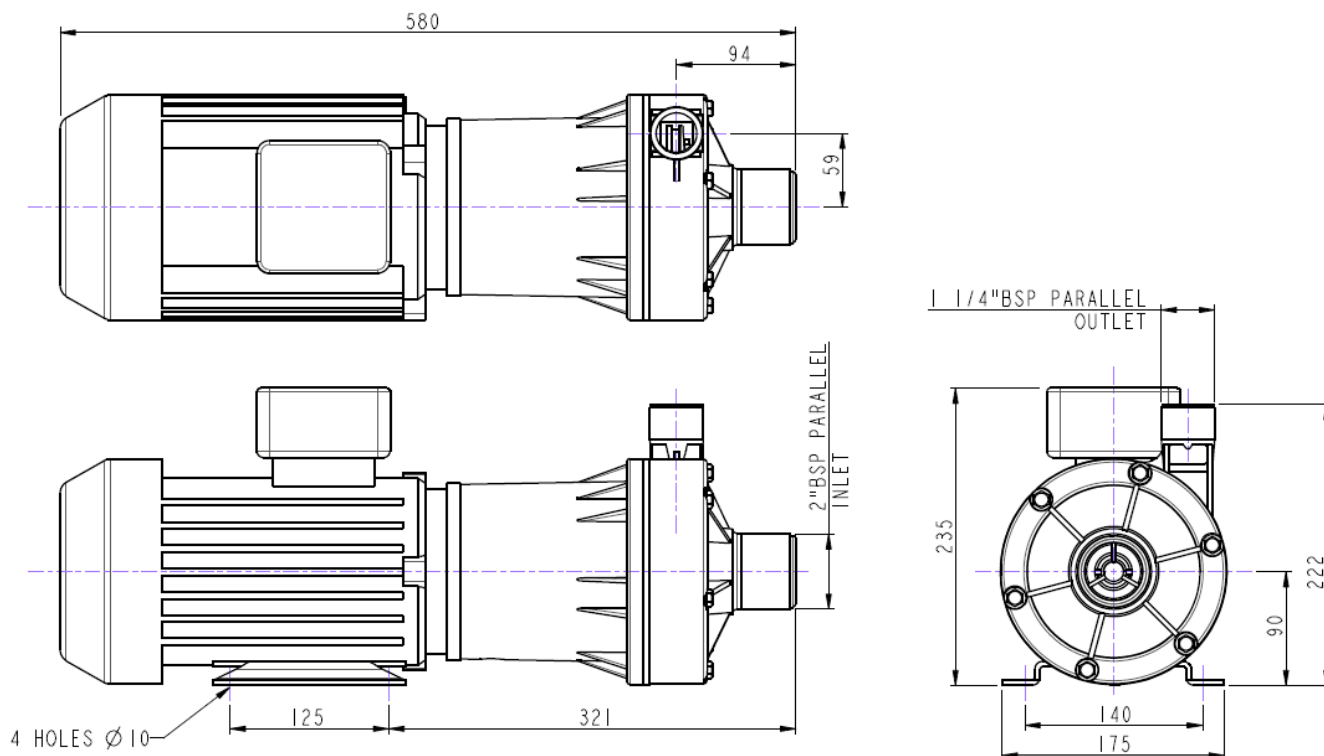

Technische Daten (Technical data) NEMP 500/20

max. Fördermenge	(discharge rate)	525 l/min (50Hz)	
max. Förderhöhe	(delivery head)	21,7 m (50Hz)	
Temperaturbereich	(temperature range)	-20...+85°C (PP)	-20...+95°C (PVDF)
max. Dichte	(max. specific gravity)	1,2 Kg/dm ³ @ max. 30 mPa s	
Gehäusedruck	(pump casing pressure)	3,0 bar	
Saugstutzen	(inlet port)	2" BSP AG (M)	
Druckstutzen	(discharge side)	1 1/4" BSP AG (M)	
Gehäusematerial	(pump casing material)	PP	PVDF
Flügelrad	(impeller)	PP	PVDF
Welle	(spindle material)	Keramik (Ceramic)	
O-Ring	(o-ring)	EPDM alternativ NBR, VITON	
Motor	(motor)	230 V, 1 Ph, 50Hz	415 V, 3 Ph, 50 Hz
Leistung	(motor capacity)	2,8 kW	
Schutzart	(protection category)	IP 55	
Gesamtgewicht	(total weight)	~ 20,6 kg	

Achtung: Die Pumpen sind nicht selbstansaugend und nicht für Trockenlauf geeignet.

Attention: These magnetically pumps are designed for use with clean fluids. Solids will cause jamming. Abrasives will reduce pump live and invalidate the warranty. The pumps are not designed to run dry.

Zentrifugalpumpe mit Magnetkupplung Magnetically coupled centrifugal pump NEMP 500/20

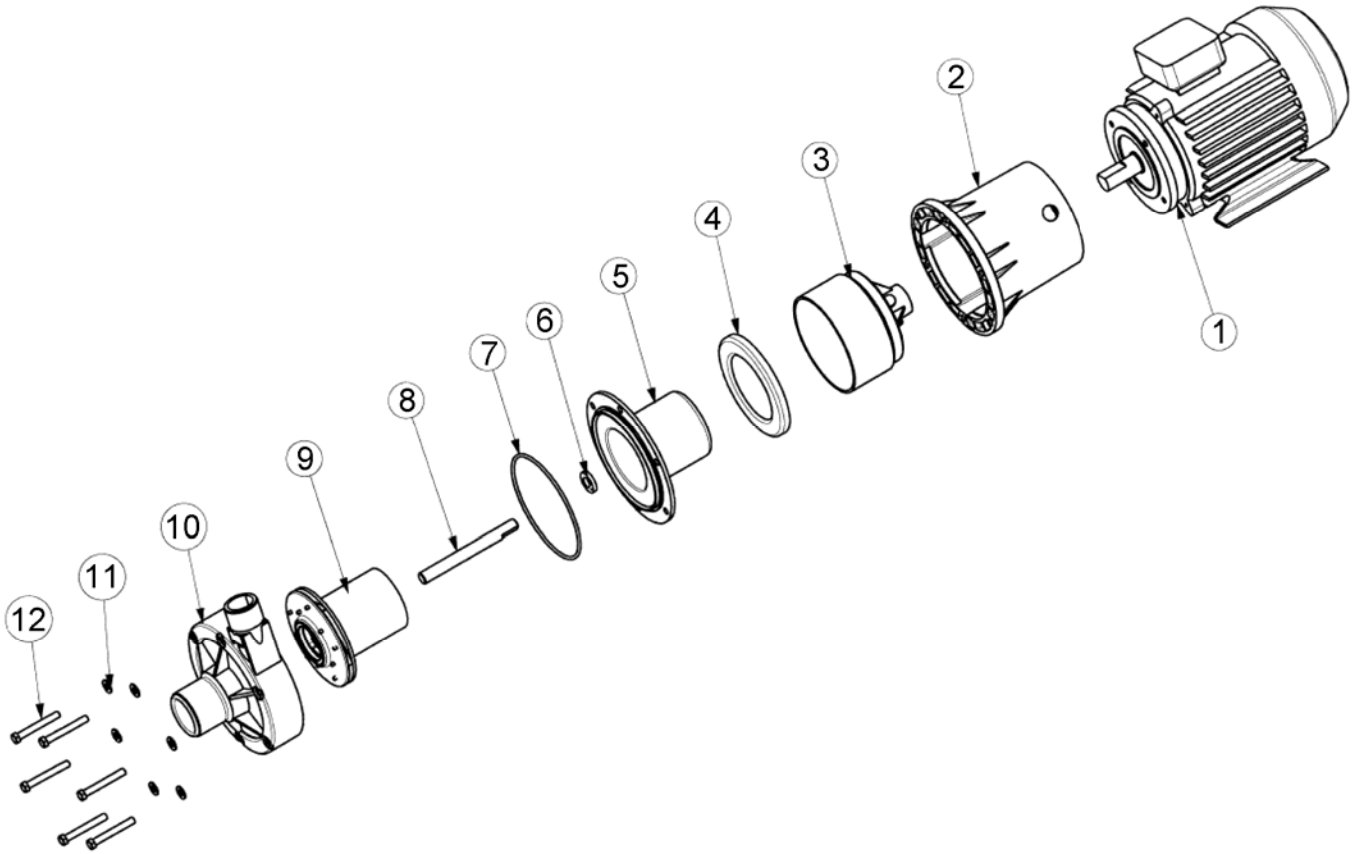

Typ	Pos.	Beschreibung	Description	Stück	Artrikel-Nr.	zusätzl. Angaben
NEMP 500/20	1	Motor	Motor	1	008870	110V 1Ph 50Hz
					008829	400V 3Ph 50Hz
					008834	400V 3Ph 50Hz High SG
NEMP 500/20	2	Laterne	Mounting Bracket	1	018376	
NEMP 500/20	3	Antriebsmagnet	Drive Magnet	1	008677	std
					018699	High SG
NEMP 500/20	4	Zentrierscheibe	Spindle Housing Support	1	008324	
NEMP 500/20	5	Spindelgehäuse	Spindle Housing	1	018319	PPS
					008335	PVDF
					028300	PP
NEMP 500/20	6	D-Gleitscheibe	D Washer	1	008330	
NEMP 500/20	7	O-Ring	O-Ring	1	008278	EPDM
					008254	Viton
NEMP 500/20	8	Spindel	Spindle	1	008329	
NEMP 500/20	9	Flügelrad	Impeller	1	028695	50Hz/High SG PP
					018698	50Hz/High SG PVDF
					018307	60Hz PP
					018308	60Hz PVDF
NEMP 500/20	10	Pumpengehäuse	Pump Body	1	018375	PP
					008371	PVDF
NEMP 500/20	11	Scheibe	Washer	8	001575	
NEMP 500/20	12	Schraube	Bolt	8	031109	