

Zentrifugalpumpe mit Magnetkupplung Magnetically coupled centrifugal pump NEMP 50/11

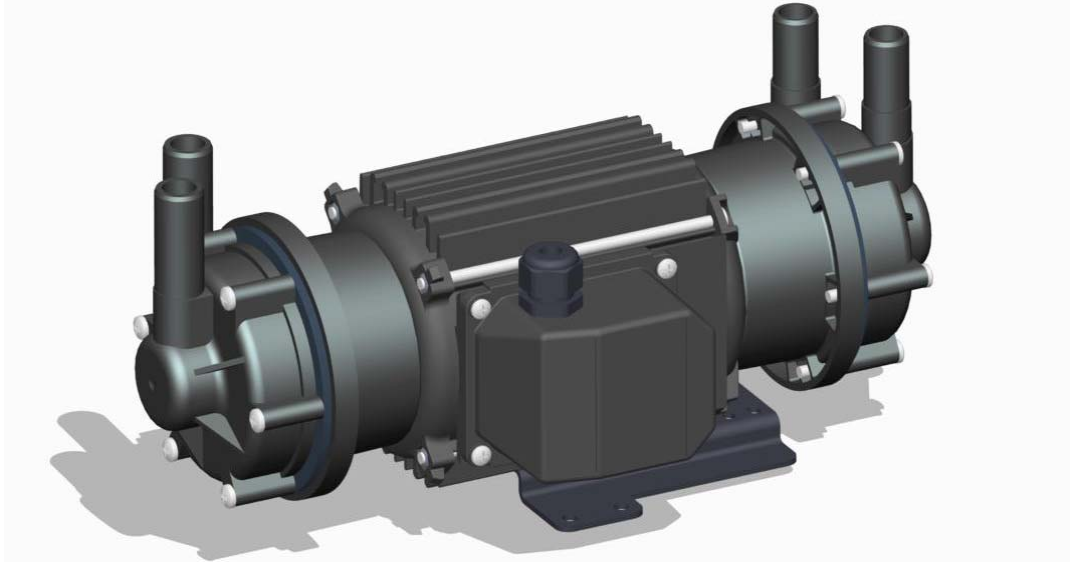

Leistungskurve* (load diagram)* 50Hz

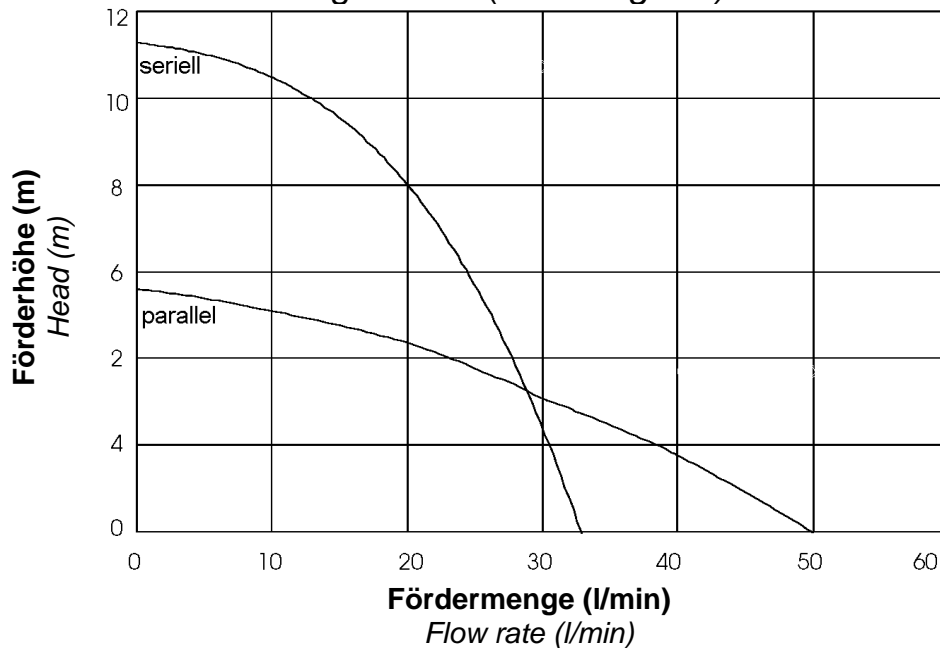

Typ Type	Volt	Ph	Hz	Saugstutzen inlet port	Druckstutzen discharge side	Artikel-Nr. PP Item number	Artikel-Nr. PPS Item number
NEMP 50/11	230	1	50	Ø 15mm glatt (plain)	Ø 15mm glatt (plain)	106903	
NEMP 50/11	230	1	50	3/8" BSP AG (M)	3/8" BSP AG (M)	106946	
NEMP 50/11	110	1	60	Ø 15mm glatt (plain)	Ø 15mm glatt (plain)		
NEMP 50/11	110	1	60	3/8" BSP AG (M)	3/8" BSP AG (M)	116952	

* Die Leistungskurve wurde mit Wasser bei 20°C ermittelt

* Performance tested with clean cold water @ 20°C

Zentrifugalpumpe mit Magnetskupplung Magnetically coupled centrifugal pump NEMP 50/11

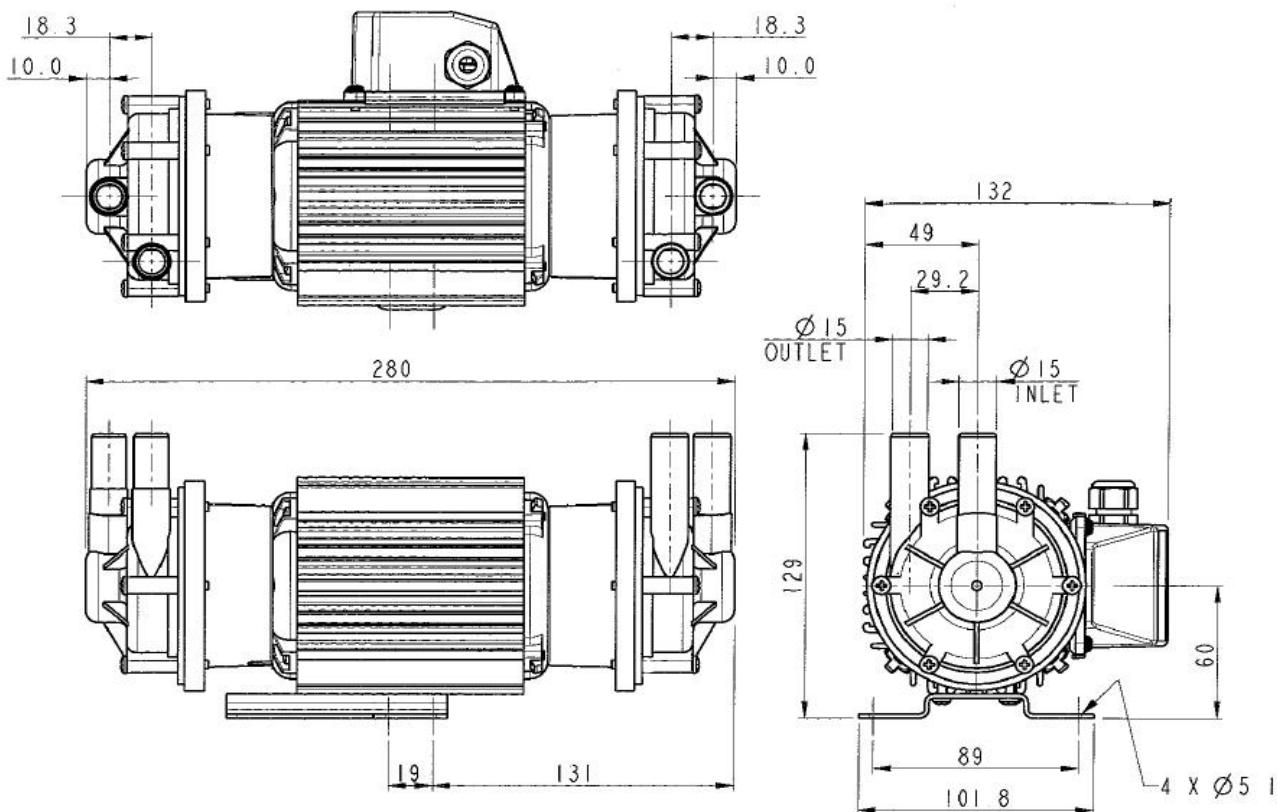

Technische Daten (Technical data) NEMP 50/11

max. Fördermenge	(discharge rate)	50 l/min (50Hz)	
max. Förderhöhe	(delivery head)	11 m (50Hz)	
Temperaturbereich	(temperature range)	-20...+85°C (PP)	
max. Dichte	(max. specific gravity)	1,2 Kg/dm ³ @ max. 30 mPa s	
Gehäusedruck	(pump casing pressure)	1,4 bar	
Saugstutzen	(inlet port)	3/8" BSP AG (M)	Ø 15 mm glatt (plain)
Druckstutzen	(discharge side)	3/8" BSP AG (M)	Ø 15 mm glatt (plain)
Gehäusematerial	(pump casing material)	PP	
Flügelrad	(impeller)	PP	
Welle	(spindle material)	Keramik (Ceramic)	
O-Ring	(o-ring)	EPDM alternativ NBR, VITON	
Motor	(motor)	230 V, 1 Ph, 50Hz 110 V, 1 Ph, 50 Hz	230 V, 1 Ph, 60 Hz 110 V, 1 Ph, 60 Hz
Leistung	(motor capacity)	155 Watt	
Schutzart	(protection category)	IP 54	
Gesamtgewicht	(total weight)	~ 3,8 kg	

Achtung: Die Pumpen sind nicht selbstansaugend und nicht für Trockenlauf geeignet.

Attention: These magnetically pumps are designed for use with clean fluids. Solids will cause jamming. Abrasives will reduce pump live and invalidate the warranty. The pumps are not designed to run dry.

Zentrifugalpumpe mit Magnetkupplung Magnetically coupled centrifugal pump NEMP 50/11

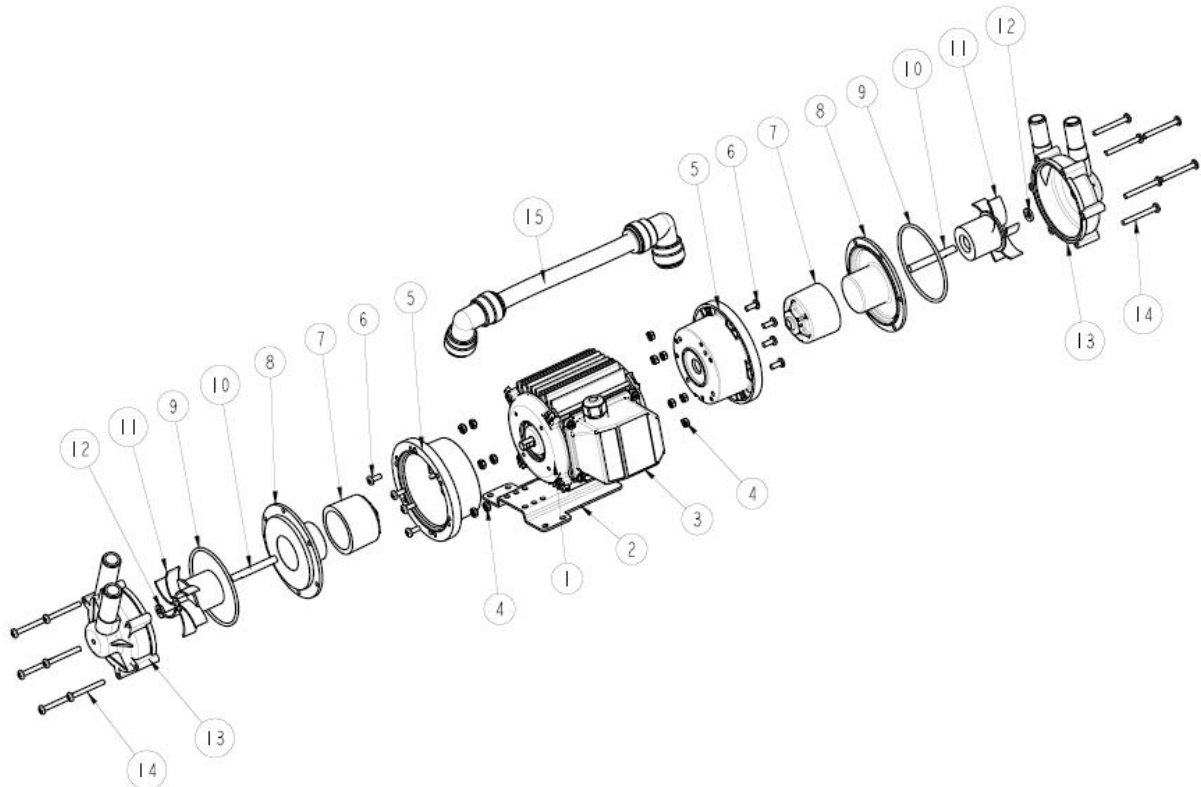

Typ	Pos.	Beschreibung	Description	Stück	Artikel-Nr.	zusätzl. Angaben
NEMP 50/11	1	Motor	Motor	1	116853	230 V
NEMP 50/11	2	Montagefuß	Mounting Foot	1	036329	
NEMP 50/11	3	Anschlusskasten	Terminal Box	1	036078	
NEMP 50/11	4	Mutter	Nut	12	032105	
NEMP 50/11	5	Laterne	Adaptor	2	036324	
NEMP 50/11	6	Schraube	Screw	8	022163	
NEMP 50/11	7	Antriebsmagnet	Drive Magnet	2	006287	
NEMP 50/11	8	Spindelgehäuse	Spindle Housing	2	016311	
NEMP 50/11	9	O-Ring	O-Ring	1	013290	EPDM
					021056	Viton
					003398	Nitrile
NEMP 50/11	10	Spindel	Spindle	1	006244	
NEMP 50/11	11	Flügelrad	Impeller	2	016355	50Hz
					026214	60Hz
NEMP 50/11	12		D Washer	N/R		
NEMP 50/11	13	Pumpengehäuse	Pump Body	1 ea	016302	LH Ø 15mm
					016303	RH Ø 15mm
					036353	LH 3/8" BSP
					036354	RH 3/8" BSP
NEMP 50/11	14	Schraube	Screw	12	022115	
NEMP 50/11	15		Cross Bar Assembly	N/R		