

Zentrifugalpumpe mit Magnetkupplung Magnetically coupled centrifugal pump GP 28/11

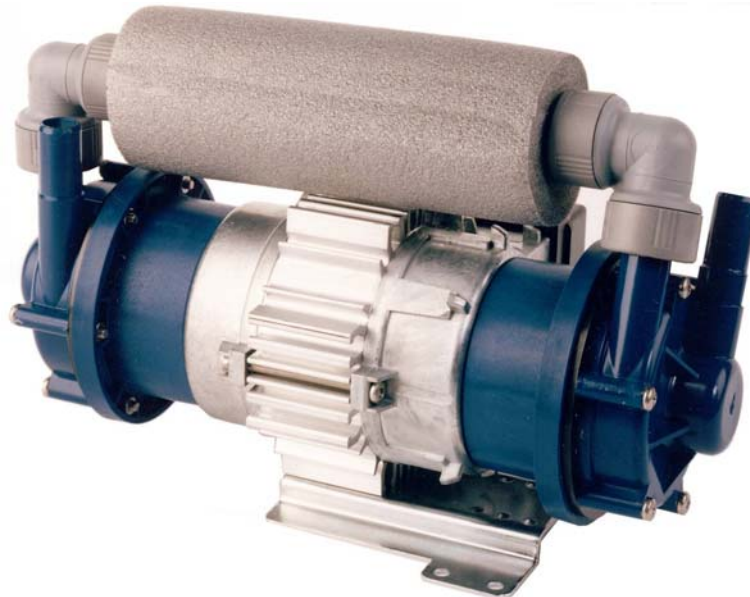

Leistungskurve 50Hz *

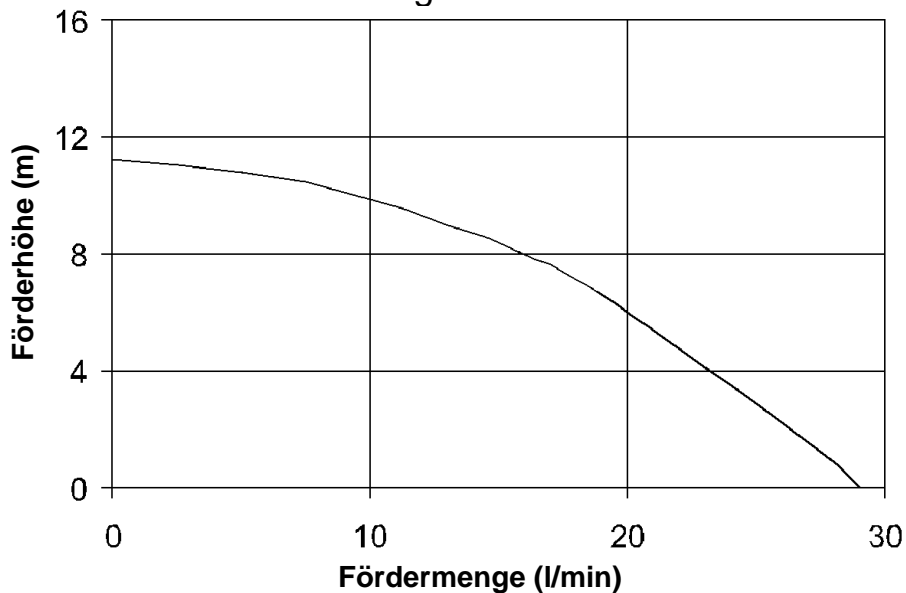

Typ	Volt	Ph	Hz	Saugstutzen	Druckstutzen	Artikel-Nr. PP	Artikel-Nr. PPS
GP 28/11	230	1	50	Ø 15mm glatt	Ø 15mm glatt		126925
GP 28/11	110	1	60	Ø 15mm glatt	Ø 15mm glatt		186901

* Die Leistungskurve wurde mit Wasser bei 20°C ermittelt

* Performance tested with clean cold water @ 20°C

Zentrifugalpumpe mit Magnetkupplung Magnetically coupled centrifugal pump GP 28/11

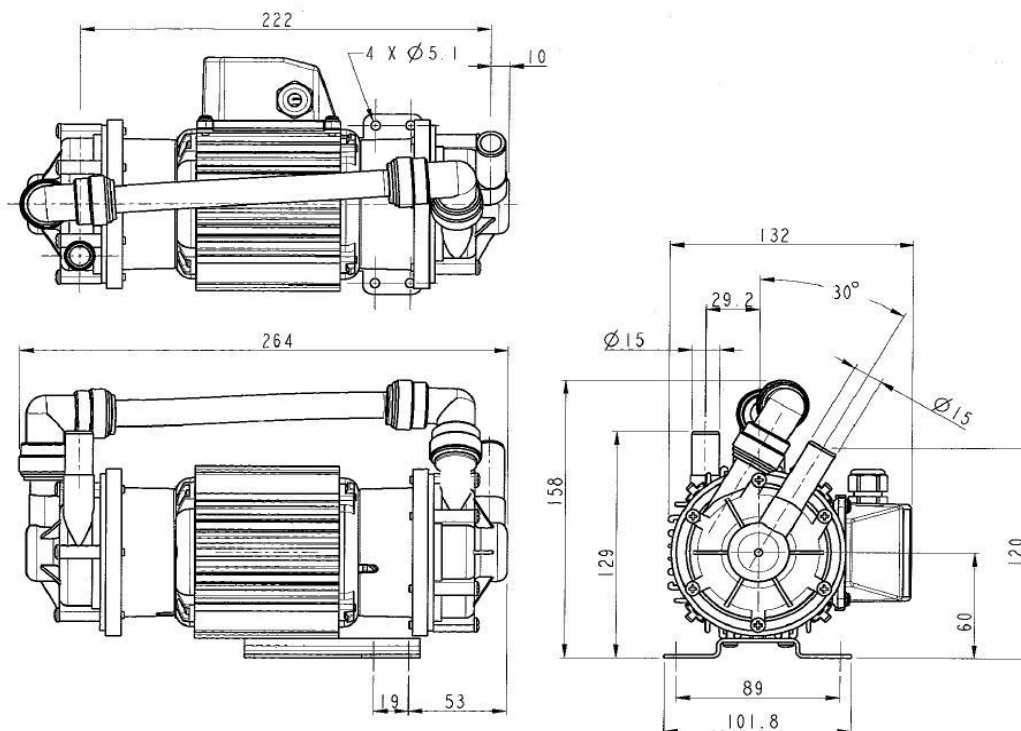

Technische Daten (Technical data)

max. Fördermenge	(discharge rate)	29 l/min (50Hz)	
max. Förderhöhe	(delivery head)	11 m (50Hz)	
Temperaturbereich	(temperature range)	-20...+85°C (PP)	
max. Dichte	(max. specific gravity)	1,0 Kg/dm ³ @ max. 30cp Viskosität	
Gehäusedruck	(pump casing pressure)	1,4 bar	
Saugstutzen	(inlet port)		Ø 15mm glatt plain
Druckstutzen	(discharge side)		Ø 15mm glatt plain
Gehäusematerial	(pump casing material)	PP	
Flügelrad	(impeller)	PP	
Welle	(spindle material)	Messing (Brass)	
O-Ring	(o-ring)	NBR (Nitrile)	
Gleitscheibe	(thrust washer)	Keramik (Ceramic)	
Motor	(motor)	230 V, 1 Ph, 50 Hz 230 V, 1 Ph, 60 Hz	
Leistung	(motor capacity)	60 Watt	
Schutzart	(protection category)	IP X5	
Gesamtgewicht	(total weight)	~ 3,2 kg	

Achtung: Die Pumpen sind nicht selbstansaugend und nicht für Trockenlauf geeignet.

Attention: These magnetically pumps are designed for use with clean fluids. Solids will cause jamming. Abrasives will reduce pump live and invalidate the warranty. The pumps are not designed to run dry.

Zentrifugalpumpe mit Magnetkupplung Magnetically coupled centrifugal pump GP 28/11

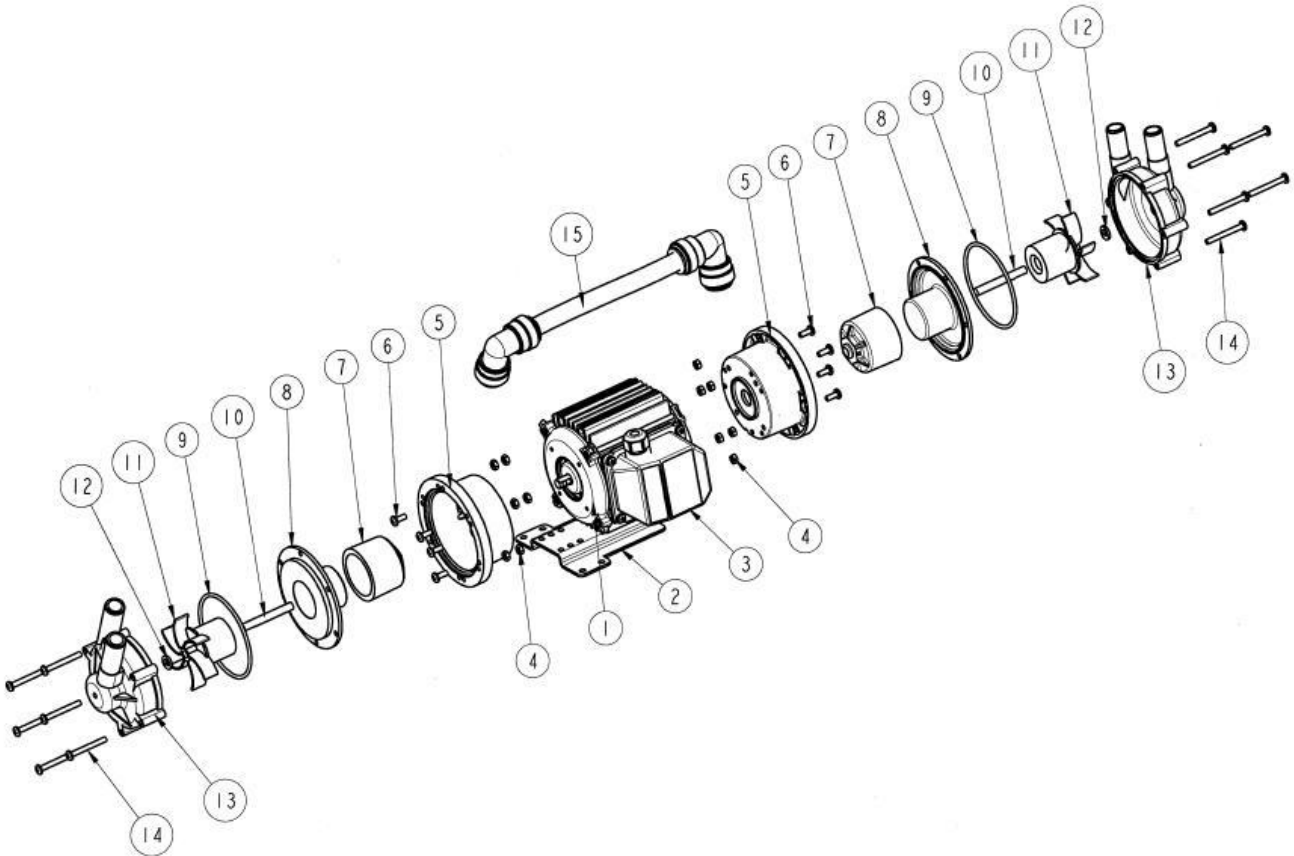

Typ	Pos.	Beschreibung	Description	Stück	Artrikel-Nr.	zusätzl. Angaben
GP 28/11	1	Motor	Motor	1	116852	230 V
GP 28/11	2	Motorfuß	Mounting Plate	1	036329	
GP 28/11	3	Anschlusskasten	Terminal Box	1	036078	
GP 28/11	4	Mutter	Nut	20	032105	
GP 28/11	5	Laterne	Adaptor	2	036324	
GP 28/11	6	Schraube	Screw	8	022163	
GP 28/11	7	Antriebsmagnet	Drive Magnet	2	006287	
GP 28/11	8	Spindelgehäuse	Spindle Housing	2	016311	
GP 28/11	9	O-Ring	O-Ring	2	003398	
GP 28/11	10	Spindel	Spindle	2	016311	
GP 28/11	11	Flügelrad	Impeller	2	016267	
GP 28/11	12	Gleitscheibe	D Washer	2	016225	
GP 28/11	13	Pumpengehäuse	Pump Body	1ea	016302	LH plain
					036353	LH threaded
					016303	RH plain
					036354	RH threaded
GP 28/11	14	Schraube	Screw	12	022115	
GP 28/11	15	Verbindungselement	Cross Bar Assembly	1	006769	