

Zentrifugalpumpe mit Magnetkupplung Magnetically coupled centrifugal pump NDP 25/4

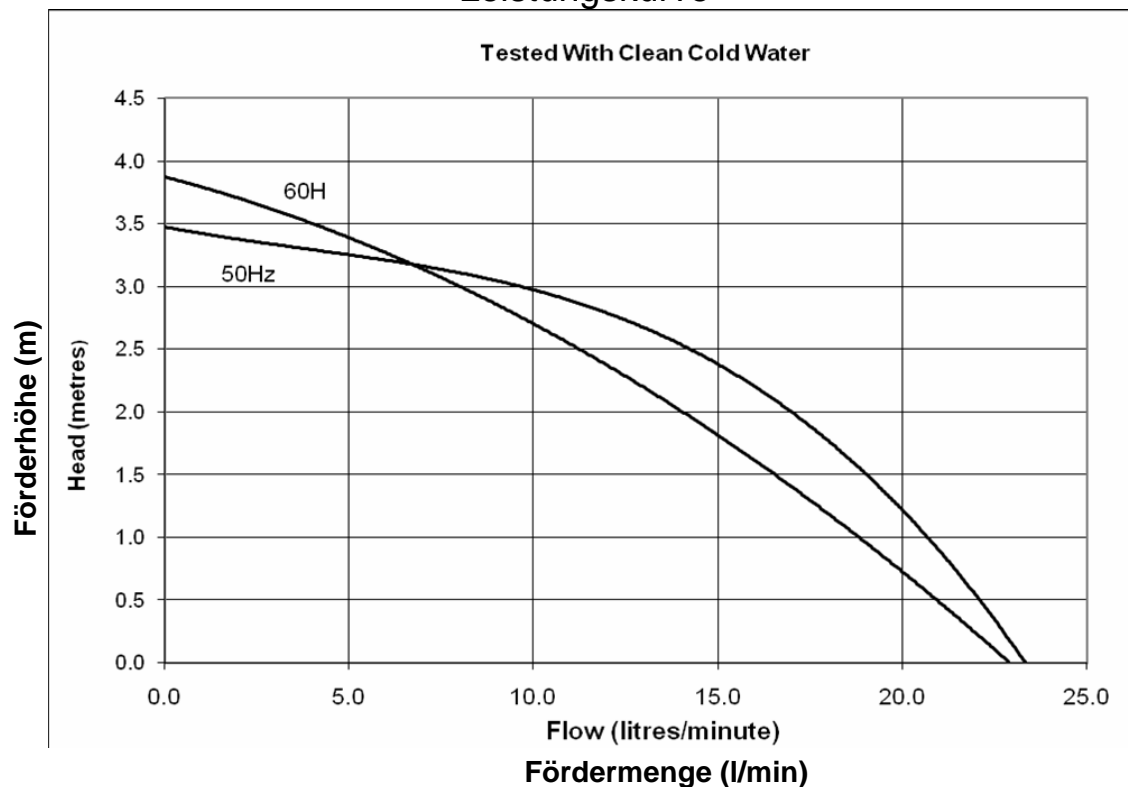

Leistungskurve*



Typ	Volt	Ph	Hz	Saugstutzen	Druckstutzen	Artikel-Nr. PP	Artikel-Nr. PPS
NDP 25/4	230	1	50	Ø 21mm glatt	Ø 16,5mm glatt	073900	
NDP 25/4	230	1	50	½" BSP AG	3/8" BSP AG	073903	
NDP 25/4	230	1	60	Ø 21mm glatt	Ø 16,5mm glatt	073952	
NDP 25/4	230	1	60	½" BSP AG	3/8" BSP AG	073953	
NDP 25/4	110	1	50	Ø 21mm glatt	Ø 16,5mm glatt	073902	
NDP 25/4	110	1	50	½" BSP AG	3/8" BSP AG		

* Die Leistungskurve wurde mit Wasser bei 20°C ermittelt

* Performance tested with clean cold water @ 20°C

Zentrifugalpumpe mit Magnetkupplung Magnetically coupled centrifugal pump NDP 25/4

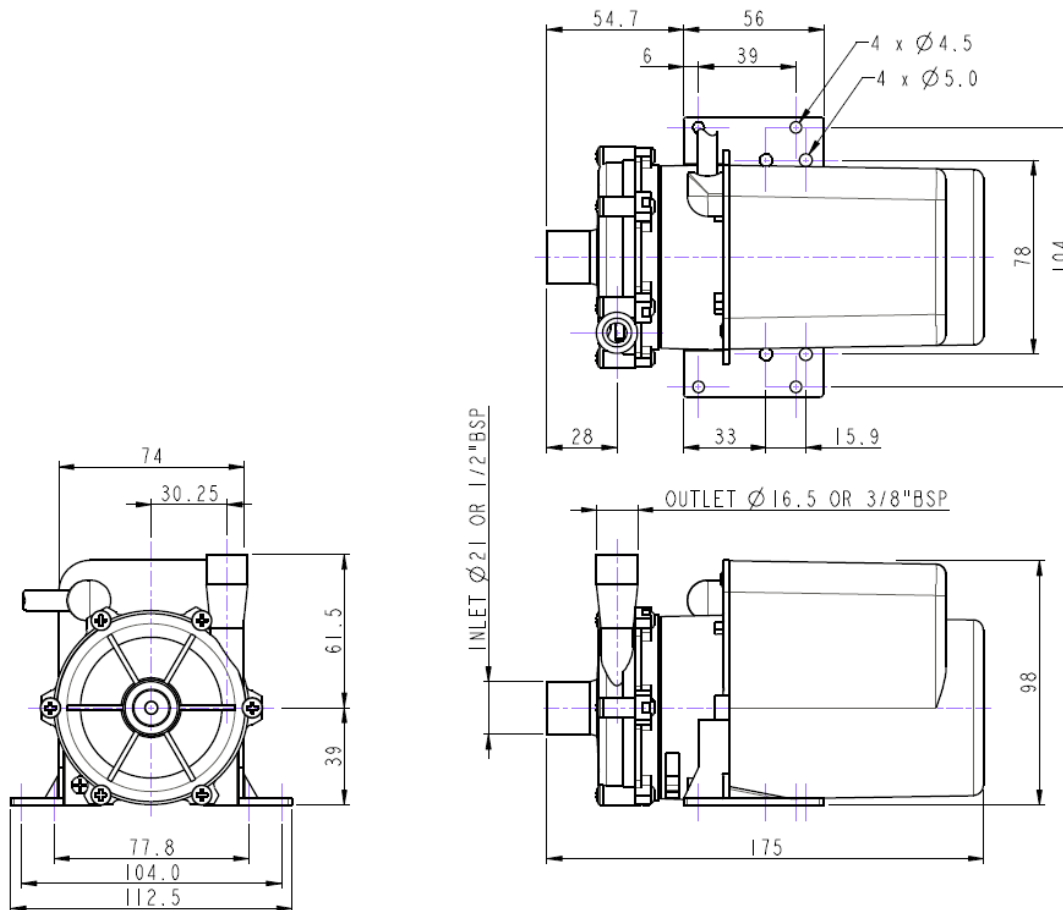

Technische Daten (Technical data) NDP 25/4

max. Fördermenge	(discharge rate)	22,5 l/min (50Hz)	23 l/min (60Hz)
max. Förderhöhe	(delivery head)	3,5 m (50Hz)	3,8 m (60Hz)
Temperaturbereich	(temperature range)	-20...+85°C (PP)	-20...+95°C (PPS)
max. Dichte	(max. specific gravity)	1,0 Kg/dm ³ @ max. 30 mPa s	
Gehäusedruck	(pump casing pressure)	1,4 bar	
Saugstutzen	(inlet port)	1/2" BSP AG	Ø 21 mm glatt (plain)
Druckstutzen	(discharge side)	3/8" BSP AG	Ø 16,5 mm glatt (plain)
Gehäusematerial	(pump casing material)	PP	PPS
Flügelrad	(impeller)	PP	PPS
Welle	(spindle material)	Keramik (Alumina ceramic)	
O-Ring	(o-ring)	EPDM alternativ NBR, VITON	
Motor	(motor)	230 V, 1 Ph, 50-60 Hz	110 V, 1 Ph, 50-60 Hz
Leistung	(motor capacity)	84 Watt (Input) 18 Watt (Output)	
Schutzart	(protection category)	IP 22	
Gesamtgewicht	(total weight)	~ 2,1 kg	

Achtung: Die Pumpen sind nicht selbstansaugend und nicht für Trockenlauf geeignet.

Attention: These magnetically pumps are designed for use with clean fluids. Solids will cause jamming. Abrasives will reduce pump live and invalidate the warranty. The pumps are not designed to run dry.

Zentrifugalpumpe mit Magnetkupplung

Magnetically coupled centrifugal pump

NDP 25/4

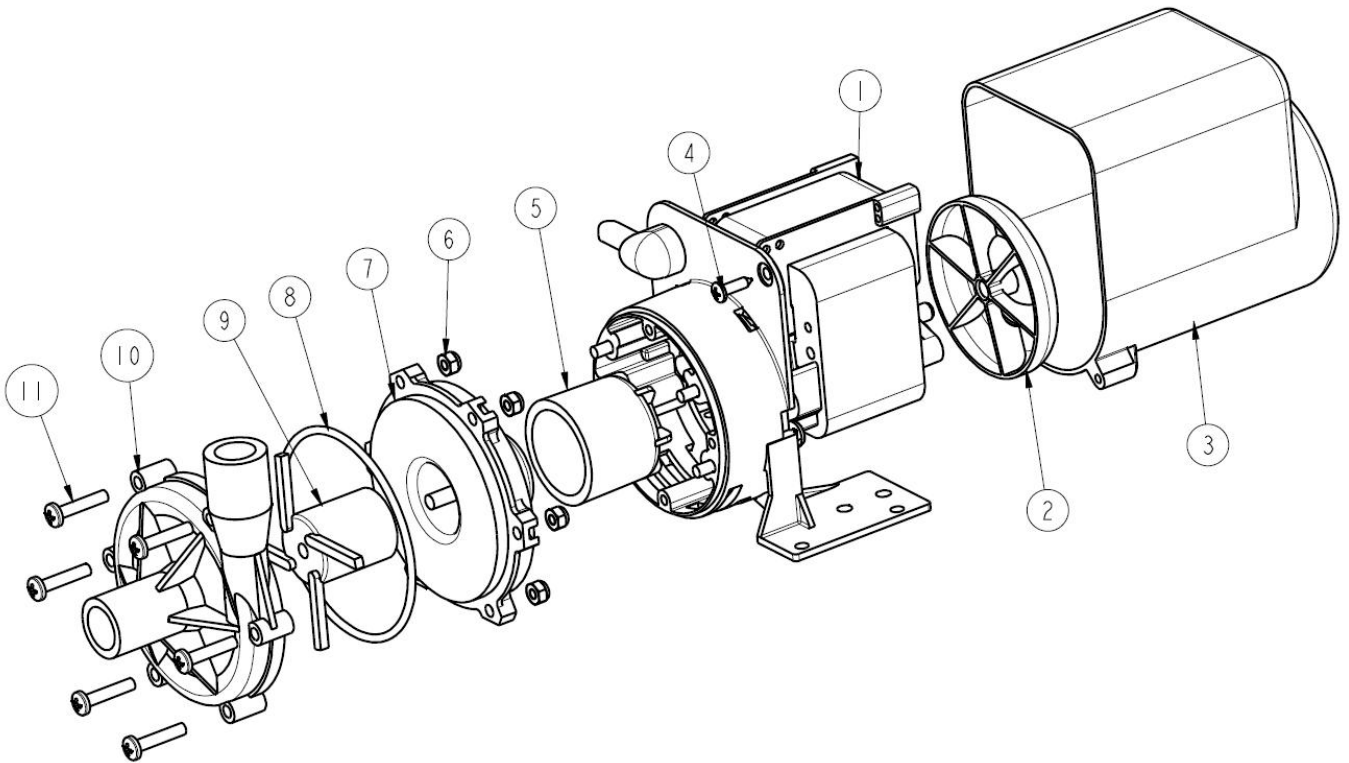

Type	Pos.	Beschreibung		Stück	Artrikel-Nr.	Ausführung
Type	Item no	Description		Quantity	Part no.	Version
NDP 25/4	1	Motor	Motor	1	-	
NDP 25/4	2	Lüfterrad	Fan	1	033322	
NDP 25/4	3	Motorgehäuse	Motor Cover	1	043335	
NDP 25/4	4	Schraube	Screw	2	001739	
NDP 25/4	5	Antriebsmagnet	Drive Magnet	1	023267	
NDP 25/4	6	Mutter	Nut	6	001564	
NDP 25/4	7	Spindelgehäuse	Spindle Housing	1	033277	
NDP 25/4	8	O-Ring	O-ring	1	013290	EPDM
					021056	Viton
					003398	Nitrile
NDP 25/4	9	Flügelrad	Impeller	1	023220	50 Hz
					023247	60 Hz
NDP 25/4	10	Pumpengehäuse	Pump Body	1	013385	Ø 21/16,5mm PP
					023261	½", 3/8" BSP PP
NDP 25/4	11	Schraube	Screw	6	001626	